

## **TAMIL NADU TEXTBOOK AND EDUCATIONAL SERVICES CORPORATION**

EVK Sampath Maaligai, DPI Campus, 68, College Road, Chennai - 600 006

Email: [jd.tntbesc@tn.gov.in](mailto:jd.tntbesc@tn.gov.in); Website: <https://textbookcorp.tn.gov.in/>

Telephone: 044-28275852

### **TENDER DOCUMENT**

#### **TENDER FOR THE SUPPLY AND DELIVERY OF GEOMETRY BOX TO THE SCHOOL CHILDREN IN TAMIL NADU FOR THE YEAR 2023-2024**

Date of Notification of Tender	30.09.2022
Pre-bid Meeting	17.10.2022 11.30 AM
Last Date for Submission of Tender	03.11.2022 11.00 AM
Date of Opening of Tenders	03.11.2022 11.30 AM
Cost of Tender document (hard copy) (Download is free)	₹ 1,000 + 18% GST = ₹ 1,180/-
Bid Processing Fee	₹ 10,000 + 18% GST = ₹ 11,800/-

### **IMPORTANT NOTICE**

This tender procedure is governed by the Tamil Nadu Transparency in Tenders Act, 1998 and the Tamil Nadu Transparency in Tender Rules, 2000 as amended from time to time. In case of any conflict between the terms and conditions in the tender document and the Tamil Nadu Transparency in Tenders Act, 1998 and The Tamil Nadu Transparency in Tender Rules, 2000, the Act and Rules shall prevail.

**TABLE OF CONTENTS**

<b>Clause</b>	<b>Topic</b>	<b>Page</b>
1.	NOTICE INVITING TENDER	1
2.	PREAMBLE	3
3.	SCOPE OF SUPPLY	3
4.	QUALIFICATION CRITERIA	4
5.	LANGUAGE OF THE TENDER	7
6.	PURCHASE OF TENDER DOCUMENT	7
7.	PRE-BID MEETING	7
8.	CLARIFICATION ON THE TENDER DOCUMENT	8
9.	AMENDMENT OF TENDER DOCUMENT	8
10.	AUTHORISATION OF THE TENDERER	8
11.	SUBMISSION OF TENDER IN TWO COVER SYSTEM	9
12.	SAMPLES SUBMISSION	10
13.	BID PROCESSING FEE	10
14.	EARNEST MONEY DEPOSIT	11
15.	VALIDITY	11
16.	OPENING AND EVALUATION OF THE TENDER	11
17.	SAMPLE EVALUATION	12
18.	PRICE BID	13
19.	EVALUATION OF THE PRICE BID & ALLOCATION OF QUANTITY	13
20.	INCREASE OR DECREASE IN TENDERED QUANTITY	14
21.	LETTER OF ACCEPTANCE	14
22.	SECURITY DEPOSIT	14
23.	AGREEMENT	15
24.	ISSUE OF PURCHASE ORDER	15
25.	POINTS OF DELIVERY	15
26.	EXTENSION OF VALIDITY PERIOD OF CONTRACT	15
27.	SCHEDULE OF SUPPLY	16
28.	SUBMISSION OF DELIVERY PLAN	17

29.	PRE-DESPTACH INSPECTION	17
30.	POST-DELIVERY TESTING	18
31.	PACKING AND LABELLING	19
32.	INSURANCE	19
33.	WARRANTY AND REPLACEMENT	19
34.	PAYMENT TERMS	20
35.	PENALTY	20
36.	LIQUIDATED DAMAGES	21
37.	CORRUPT OR FRAUDULENT PRACTICES	21
38.	TERMINATION OF CONTRACT	22
39.	BLACKLISTING	23
40.	FORCE MAJEURE	24
41.	GENERAL CONDITIONS	24
42.	DISPUTE RESOLUTION BOARD	25
43.	ARBITRATION	25
44.	JURISDICTION OF THE COURT	26

<b>LIST OF ANNEXURES</b>		
<b>Annexure</b>	<b>Topic</b>	<b>Page</b>
I-A.	TECHNICAL SPECIFICATIONS FOR GEOMETRY BOX	27
I-B.	DRAWINGS	29
I-C.	RAW MATERIALS	38
I-D.	TESTING PROCEDURES	40
II.	LETTER OF THE TENDERER	43
III.	COVERING LETTER FOR TECHNICAL PROPOSAL	45
IV.	DETAILS OF THE TENDERER	48
V.	SAMPLES SUBMISSION FORM	50
VI.	ANNUAL TURNOVER STATEMENT	51
VII-A.	DETAILS OF WORK ORDERS COMPLETED	52
VII-B.	CHARTERED ACCOUNTANT CERTIFICATE FOR QUANTITY SUPPLIED	53
VIII.	CHARTERED ENGINEER CERTIFICATE	54
IX.	FORMAT FOR BANK'S CERTIFICATE FOR CASH CREDIT FACILITIES/OWN FUNDS	58
X.	NET WORTH CERTIFICATE	59
XI-A.	DECLARATION FOR NOT HAVING BLACKLISTED	60
XI-B.	DECLARATION FOR NON-ADVERSE PERFORMANCE	61
XII.	DECLARATION FOR NOT HAVING TAMPERED TENDER DOCUMENT	62
XIII.	DECLARATION FOR MINIMUM OFFERED QUANTITY	63
XIV.	DECLARATION FOR ACCEPTING TERMS AND CONDITIONS OF TENDER	64
XV.	CLARIFICATION ON TENDER DOCUMENT	65
XVI.	CHECKLIST OF DOCUMENTS - PART-A (TECHNICAL BID)	66
XVI.	CHECKLIST OF DOCUMENTS - PART-B (PRICE BID)	69
XVII.	COVERING LETTER FOR FINANCIAL PROPOSAL (PRICE BID)	70
XVIII.	FINANCIAL PROPOSAL (Part-B)	71
XIX.	FORMAT FOR BANK GUARANTEE FOR SECURITY DEPOSIT	72
XX.	MODEL AGREEMENT FORM	74
XXI.	LIST OF DISTRICT AND BLOCK EDUCATIONAL OFFICES IN TAMIL NADU	87
XXII.	DELIVERY SCHEDULE FOR THE ORDERED QUANTITY	100
XXIII.	UNDERTAKING TOWARDS JURISDICTION OF LEGAL PROCEEDINGS	101

1.	<b>NOTICE INVITING TENDER</b>	
Tender Ref. RC.No. 9359/PUR-II/2022		
1.1 Sealed tenders are invited from manufacturer/supplier of Geometry boxes (Mathematical Drawing Instruments). National bidding will be conducted under two-cover system conforming to the Tamil Nadu Transparency in Tenders Act, 1998 and the Tamil Nadu Transparency in Tender Rules, 2000 as amended from time to time.		
1.	Name of the work	Supply and delivery of <b>13,42,757</b> Geometry boxes for the School Children in Tamil Nadu for the year 2023 - 2024.
2.	Cost of Tender Document (Hard copy)	₹ 1,000 + 18% GST aggregating to ₹ 1,180/- payable in the form of Demand Draft / Banker's cheque drawn from a Scheduled Commercial Bank in favour of "Tamil Nadu Textbook and Educational Services Corporation" payable at Chennai
3.	Purchase of Tender Documents from:	i. Assistant Director (Purchase), Tamil Nadu Textbook and Educational Services Corporation, EVK Sampath Maaligai, 1 <sup>st</sup> Floor, 68, College Road, Chennai-600 006. ii. The same may also be downloaded at <b>free of cost</b> from the following websites: a) <a href="http://www.textbookcorp.tn.gov.in">http://www.textbookcorp.tn.gov.in</a> b) <a href="http://www.tenders.tn.gov.in">http://www.tenders.tn.gov.in</a>
4	Sale period of Tender Document	On all working days from 30.09.2022 to 02.11.2022 between 10.00 AM and 05.45 PM
5.	Earnest Money Deposit (EMD)	<b>₹ 2,55,000/-</b>
6.	Date of Pre-Bid Meeting	17.10.2022 at 11.30 AM
7.	Last Date and Time for Submission of Tender	03.11.2022 up to 11.00 AM

8.	Due date and time for opening of Technical Bids	03.11.2022 at 11.30 AM. If the due date happens to be a holiday, the Tenders will be received and opened on the next working day.
9.	Contract Period	One year from the date of agreement.

- 1.2 **Consortium Tenders are not acceptable.** For all other conditions / instructions, please refer tender document.
- 1.3 The Corporation shall not be responsible for any postal delay or any loss of Tenders in transit.
- 1.4 The Managing Director, Tamil Nadu Textbook and Educational Services Corporation reserves the right to amend or withdraw any of the Terms and Conditions in the Tender Document or to cancel / reject any one or all the tenders received without giving any notice or assigning any reason therefor.
- 1.5 The Tenderers are requested to view the websites - <http://www.textbookcorp.tn.gov.in> & <http://www.tenders.tn.gov.in> for any changes / amendments / corrigendum in the Tender, which may be issued at any time before the last date for submission of the Tender.

Managing Director and Tender  
Inviting Authority,  
Tamil Nadu Textbook and Educational Services  
Corporation,  
Chennai-600006

2.	<b>PREAMBLE</b>
2.1	<p>In order to implement the announcements of the Hon'ble Chief Minister pertaining to the <b>SCHEME OF SUPPLY OF COST-FREE GEOMETRY BOX</b> to the School Children studying in Government &amp; Aided Schools in Tamil Nadu for the year 2023 - 2024, the Tamil Nadu Textbook and Educational Services Corporation, hereinafter, called as the "<b>Corporation</b>", has been entrusted with the task of procuring quality Geometry boxes and distributing the same in time to the school children.</p>
2.2	<p>The Corporation has proposed to procure 13,42,757 Geometry boxes, which are to be delivered to the 534 designated delivery points of Block Educational Officers (BEO) / District Educational Officers (DEO) throughout Tamil Nadu.</p>
2.3	<p>Accordingly, the Corporation invites sealed tenders from eligible tenderers in "Two Cover System" for the supply and delivery of Geometry box. The Tender notification has been published fixing the date of opening of tender as 03.11.2022.</p>
2.4	<p>The successful tenderer(s) shall work closely with the Corporation in achieving the scheduled targets in terms of quality and quantity.</p>
3.	<b>SCOPE OF SUPPLY</b>
<p>The scope of supply would, <i>inter-alia</i>, involve the following:</p> <p>3.1 The successful tenderer(s) shall supply the awarded quantity of Geometry box within the contract period of 75 days in compliance with the technical specifications given in the <b>Annexure I-A, I-B and I-C</b>.</p> <p>3.2 The Geometry box are to be delivered at the 534 designated delivery points located throughout Tamil Nadu as per <b>Annexure - XXI</b>.</p>	



4. QUALIFICATION CRITERIA		
Clause	Qualification Criteria	Supporting Documents/Remarks
4.1	<p><b>Legal entity:</b></p> <p>The tenderer shall be a Registered legal entity in India.</p>	<p>(i) In case of Private / Public Limited Companies,</p> <ul style="list-style-type: none"> <li>• Copy of Incorporation Certificate issued by the Registrar of Companies.</li> <li>• Copy of Memorandum and Articles of Association</li> </ul> <p>(ii) In case of Partnership Firm,</p> <ul style="list-style-type: none"> <li>• Copy of LLP Registration/ Registered Partnership deed</li> </ul> <p>(iii) In case of Proprietorship,</p> <ul style="list-style-type: none"> <li>• Copy of GST Registration certificate</li> </ul>
4.2	<p><b>Manufacturer / Supplier:</b></p> <p>The tenderer shall be a manufacturer / supplier of Geometry boxes in the last 3 (three) financial years as on 31<sup>st</sup> March 2022.</p>	<p>(i) Copy of GST Registration certificate</p> <p>(ii) GST Annual return copies for the last 3 financial years i.e., 2019-2020, 2020-2021 and 2021-2022</p> <p>(iii) Copy of legal contractual agreement with manufacturer(s) of Geometry Boxes with validity for at least three years beyond the tender opening date (only for Supplier).</p>
4.3	<p><b>Average annual turnover:</b></p> <p>The tenderer should have reported an Average Annual Turnover of minimum ₹ 1.05 Crores in the business of Geometry box and mathematical drawing instruments in 3 (three) consecutive financial years i.e., 2018-2019, 2019-2020 and 2020-2021 (or) 2019-2020, 2020-2021 and 2021-2022.</p>	<p>(i) The average annual turnover duly certified by Chartered Accountant with UDIN as per enclosed <b>Annexure - VI</b>.</p> <p>(ii) The Annual Report with all schedules and Form 3CD / certified copies of Balance Sheet, Profit &amp; Loss statement for the last 3 (three) consecutive financial years.</p>

		(iii) Income Tax Returns and Tax Audit Form 3CD for the last 3 (three) consecutive financial years.
4.4	<p><b>Past experience:</b></p> <p>The tenderer should have supplied at least 5% of the tendered quantity of Geometry box to any organisation in any one of the last 3 Financial Years i.e., 2019-2020, 2020-2021 and 2021-2022.</p>	<p>(i) Copies of Work Order / Purchase Order in support of supply as per <b>Annexure VII-A.</b></p> <p>(ii) Certificate issued by Chartered Accountant on the quantity of Geometry box supplied as per <b>Annexure VII-B.</b></p>
4.5	<p><b>Production capacity:</b></p> <p>The tenderer's unit (or tenderer's contract manufacturing unit, in case of Supplier) shall have production capacity of at least 5,000 Geometry boxes per day.</p>	Chartered Engineer's Certificate for infrastructure and production capacity at tenderer's manufacturing unit (or tenderer's contract manufacturing unit, in case of Supplier) as per enclosed <b>Annexure - VIII.</b>
4.6	<p><b>Cash credit facility:</b></p> <p>The tenderer should have Cash Credit facility or own funds of at least ₹ 65.00 lakhs. The tenderer's account should not have been declared as non-performing asset (NPA).</p>	Letter from a Scheduled Commercial Bank (on Bank's letterhead) in support of cash credit facility or own funds as per enclosed <b>Annexure - IX</b> and that the tenderer's account is not NPA.
4.7	<p><b>Net worth:</b></p> <p>The tenderer should have a positive net worth as on March 31, 2022.</p>	The Net Worth Certificate duly certified by Chartered Accountant with UDIN as per enclosed <b>Annexure - X.</b>
4.8	<p><b>Not blacklisted in last 5 years:</b></p> <p>The tenderer should not have been blacklisted by the Corporation or Central / State Government departments / Quasi Government organisations / Local government bodies / PSU during the last 5 years as on the date of tender opening. Even if the blacklisting was</p>	<p>(i) The declaration form as per <b>Annexure XI-A</b> should be enclosed.</p> <p>(ii) Termination / full or partial Cancellation / forfeiture of EMD and/or Security Deposit / non-execution of contract agreement, pertaining to any tender of the</p>

	<p>revoked, the tenderer is <b>not eligible</b> to participate in the tender.</p>	<p>Corporation in the last 5 years as on date of tender opening, will entail disqualification.</p> <p>(iii) Further, if the tenderer is found blacklisted in India before award of contract by any Government agency, the Tender will be rejected.</p>
4.9	<p><b>Non-adverse performance:</b></p> <p>There should not have been any adverse performance by the tenderer in any contract to the Corporation in the last 3 financial years i.e., in 2019-20, 2020-21 and 2021-22 in terms of the following:</p> <p>a) Non-execution of Agreement b) Forfeiture of Security deposit c) Non-supply of ordered quantity either partially or fully. d) Termination of contract</p>	<p>The declaration form as per <b>Annexure XI-B</b> should be enclosed.</p>
4.10	<p><b>In-house QC &amp; testing laboratory:</b></p> <p>The tenderer's unit (or contract manufacturer's unit, in case of Supplier) should have requisite in-house Quality Control laboratory and testing facilities to undertake tests prescribed in Annexure I-D.</p>	<p>Chartered Engineer's Certificate of the tenderer's manufacturing unit (or contract manufacturer's unit, in case of Supplier) should include details of <b>Quality Control laboratory equipment and testing facility, which are managed by qualified &amp; experienced QC personnel</b> as per enclosed <b>Annexure - VIII</b>.</p>
4.11	<p><b>Minimum offer quantity:</b></p> <p>The tenderer should offer to supply a minimum quantity of 2,00,000 Geometry boxes.</p>	<p>Declaration form as per enclosed <b>Annexure - XIII</b>.</p>
4.12	<p><b>Local Office in Chennai:</b></p> <p>The tenderer should have a local office in Chennai</p>	<p>Documentary proof of Address for having a local office in Chennai.</p>

5.	<b>LANGUAGE OF THE TENDER</b>
<p>The Tender submitted by the tenderer as well as all correspondence and documents relating to the Tender shall be in English language only. If the supporting documents are in a language other than English/Tamil, the notarized translated English version of the documents should also be enclosed. <b>Tender received without such translation copy will be rejected.</b></p>	
6.	<b>PURCHASE OF TENDER DOCUMENT</b>
<p>6.1 The tender document shall be obtained from Tamil Nadu Textbook and Educational Services Corporation, EVK Sampath Maaligai, DPI Campus, 68, College Road, Chennai - 600 006 on payment of ₹ 1,000 + 18% GST aggregating to ₹ 1,180/- payable in the form of Demand Draft drawn on any Scheduled Commercial Bank in favour of “Tamil Nadu Textbook and Educational Services Corporation” payable at Chennai or it can be downloaded from <a href="https://www.textbookcorp.tn.gov.in">https://www.textbookcorp.tn.gov.in</a> and <a href="http://www.tenders.tn.gov.in">www.tenders.tn.gov.in</a> free of cost. For the downloaded tender document, the tenderer need not enclose the tender document cost but should give a declaration for not having tampered the Tender document downloaded (as per Annexure - XII).</p> <p>6.2 The tender document can be purchased on all working days from 30.09.2022 to 02.11.2022 between 10.00 AM and 05.45 PM.</p>	
7.	<b>PRE-BID MEETING</b>
<p>7.1 There will be a pre-bid meeting on 17.10.2022 at 11.30 AM in the Tamil Nadu Textbook and Educational Services Corporation, DPI Campus, Chennai 600 006 during which the prospective tenderers can get clarifications about the tender. The tenderers shall send their queries, if any, in writing by email to <a href="mailto:jd.tntbesc@tn.gov.in">jd.tntbesc@tn.gov.in</a> as per the format given in Annexure -XV, so as to reach the Corporation at least 48 hours prior to the pre-bid meeting date.</p> <p>7.2 The tenderers are advised to check <a href="https://www.textbookcorp.tn.gov.in">https://www.textbookcorp.tn.gov.in</a> and <a href="http://www.tenders.tn.gov.in">www.tenders.tn.gov.in</a> for up-to-date information like change in date / venue etc. of pre-bid meeting as Corporation may not be able to identify and communicate with the prospective tenderers at this stage. Not attending pre-bid meeting is not a disqualification.</p>	

<b>8.</b>	<b>CLARIFICATION ON THE TENDER DOCUMENT</b>
<p>Any discrepancies, omissions, ambiguities or conflicts in the tender document or any doubts as to their meaning and any request for clarification may be sent in writing to “The Managing Director, Tamil Nadu Textbook and Educational Services Corporation, EVK Sampath Maaligai, DPI Campus, 68, College Road, Chennai - 600 006” or through email to <b>jd.tntbesc@tn.gov.in</b> as per <b>Annexure - XV</b>. The Managing Director, will review the same and where information sought is not clearly indicated or specified in the tender documents, will issue a clarifying bulletin to all those who have purchased the tender documents and will also upload such clarification on <a href="https://www.textbookcorp.tn.gov.in">https://www.textbookcorp.tn.gov.in</a> and <a href="http://www.tenders.tn.gov.in">www.tenders.tn.gov.in</a>. The Managing Director will neither make nor be responsible for any oral instructions. Request for clarification should be brought to the notice of the Managing Director, in writing, before 48 hours of opening of the tender.</p>	
<b>9.</b>	<b>AMENDMENT OF TENDER DOCUMENT</b>
<p>9.1 At any time after the issue of the tender documents and before the opening of the tender, the Tender Inviting Authority may make any changes, modifications or amendments to the tender documents and shall send intimation of such change to all those who have purchased the original tender documents and upload corrigendum on the websites <a href="https://www.textbookcorp.tn.gov.in">https://www.textbookcorp.tn.gov.in</a> and <a href="http://www.tenders.tn.gov.in">www.tenders.tn.gov.in</a> for the information of those who have downloaded the tender documents from the website.</p> <p>9.2 In case any one tenderer asks for a clarification to the tender documents before 48 hours of the opening of the Tender, the Tender Inviting Authority shall ensure that a reply is sent and copies of the reply to the clarification sought shall be communicated to all those who have purchased the tender documents without identifying the source of the query and upload such clarification to the designated websites <a href="http://www.textbookcorp.tn.gov.in">http://www.textbookcorp.tn.gov.in</a> and <a href="http://www.tenders.tn.gov.in">www.tenders.tn.gov.in</a> for the information of those who have downloaded the tender documents from the website, without identifying the source of the query.</p>	
<b>10.</b>	<b>AUTHORISATION OF THE TENDERER</b>
<p>10.1 The Tender should be signed by the person who is authorised for the same by the tenderer’s organisation. Authorisation from the appropriate authority to sign the tender document must be enclosed along with Technical Bid. Tenders received without such authorisation shall be rejected.</p>	

10.2 Letter of Authorisation / Power of Attorney is required only when the signing person does not hold the power to sign the document as per Articles of Association. The Power of Attorney should be on a Non-Judicial Stamp Paper of value of not less than ₹ 100/- in case of Public Sector Undertakings / Public / Private Limited Companies. In case, the signing person being the Managing Director / CEO and is delegated the power to sign all the documents, separate Power of Attorney is not required and only Extract of the Minutes of the Board Resolution to this effect has to be enclosed.

**11. SUBMISSION OF TENDER IN TWO COVER SYSTEM**

11.1 Every page of the terms and conditions of the tender document should be signed and enclosed with the tender, in token of having accepted the tender conditions, failing which the tender will be rejected summarily.

11.2 Tenders should be submitted in two parts:

- i. Part-A will cover technical bid and
- ii. Part-B will cover price bid

11.3 Tenderers should ensure submission of all documents along with Part-A and Part- B proposal as per the Checklist given in **Annexure - XVI**. Omission or failure to furnish any or all the required information in the tender document shall result in rejection of the tender.

11.4 Tenderers are requested to submit Part-A and Part-B in two separate sealed covers superscribing as 'Part-A' and 'Part-B' respectively. These two Parts namely Part-A and Part-B must be placed in a separate sealed cover superscribed as "Tender for the supply of Geometry Box for the year 2023-2024" and addressed to "The Managing Director, Tamil Nadu Textbook and Educational Services Corporation, EVK Sampath Maaligai, DPI Campus, 68, College Road, Chennai - 600 006", containing the name and address of the Tenderer. **Tenders submitted in unsealed cover would be summarily rejected.**

11.5 Tenders should be dropped only in the tender box kept at "Tamil Nadu Textbook and Educational Services Corporation, EVK Sampath Maaligai, DPI Campus, 68, College Road, Chennai - 600 006" on or before 11.00 AM on 03.11.2022. Tenders will not be received by hand.

11.6 Alternatively, the tenders can be submitted through registered post so as to reach the above address on or before 11.00 AM on 03.11.2022. Tenders received after the specified time will not be considered and Corporation will not be liable or responsible for any postal delays.

- 11.7 A tender once submitted shall not be permitted to be altered or amended.
- 11.8 A Chartered Engineer's Certificate in support of infrastructure and production capacity of tenderer's manufacturing unit (or tenderer's contract manufacturer's unit, in case of Supplier) as per enclosed **Annexure-VIII** with details of production machineries, in-house Quality Control Lab/Testing Equipment, qualified and experienced QC personnel employed, utilities, raw material store, finished goods store, dispatch area, etc. has to be submitted.
- 11.9 **The tender document shall compulsorily be spiral bound & indexed with page numbers.**
- 11.10 The tenderer shall enclose profile of the Company/Firm along with a Video CD covering the entire manufacturing process from the raw materials stage to the stage of finished products.

<b>12.</b>	<b>SAMPLES SUBMISSION</b>
------------	---------------------------

- 12.1 Along with the Technical Bid, the tenderer shall submit three samples of each piece of mathematical drawing instrument, metal box and inner compartment used for Geometry boxes as per **Annexure I-C** in a sealed cover superscribing "Sample Raw materials".
- 12.2 The tenderer shall submit three samples of Geometry boxes manufactured as per technical specifications mentioned in the **Annexure I-A, IB, I-C and I-D** of Tender Document in a sealed cover superscribing "Sample Geometry boxes".
- 12.3 The tenders received without sample pieces of mathematical drawing instruments and Sample Geometry boxes (as per **Annexure - V**) shall be rejected and the tenderer's Financial bid will not be opened.

<b>13.</b>	<b>BID PROCESSING FEE</b>
------------	---------------------------

- 13.1 The Tender shall be accompanied by a Bid Processing Fee (Non-Refundable) of ₹ 10,000 + 18% GST aggregating to ₹ 11,800/- (Rupees Eleven Thousand Eight Hundred Only) in the form of Demand Draft / Banker's cheque drawn on any Scheduled Commercial Bank in favour of the "Tamil Nadu Textbook and Educational Services Corporation, Chennai".
- 13.2 Bid Processing Fee in any other form will not be accepted.
- 13.3 Any request of the tenderer claiming exemption from payment of Bid Processing Fee under any circumstances will be rejected and their Part-B price bid will not be opened.

13.4 Tender is liable to be rejected in case the tenderer fails to remit the Bid Processing Fee.

**14. EARNEST MONEY DEPOSIT**

14.1 The Tender shall be accompanied by an Earnest Money Deposit (EMD) to a value of ₹ 2,55,000/- (Rupees Two lakhs fifty five thousand only) in the form of Demand Draft / Banker's cheque drawn on any Scheduled Commercial Bank in favour of the "Tamil Nadu Textbook and Educational Services Corporation, Chennai".

14.2 The EMD in any other form will not be accepted. EMD will be returned to the unsuccessful tenderers within 30 days from the date of issue of Purchase Orders.

14.3 The EMD will be retained in the case of successful tenderer(s) and it will not earn any interest and will be dealt with, as provided in the terms and conditions of the tender.

14.4 As per the provision under Rule 14(1) of Tamil Nadu Transparency in Tender Rules 2000, any category of tenderers specifically exempted by the Government from the payment of EMD are not required to make the deposit along with the bid. The document submitted for exemption of EMD should have the validity and the tendered item in the list of products. The tender with invalid document for EMD exemption will be summarily rejected.

14.5 EMD is liable to be forfeited in case the tenderer fails to remit the Security Deposit or execute the Agreement after the issue of Letter of Acceptance by the Corporation.

**15. VALIDITY**

The rate quoted in the Tender shall be valid for the acceptance by the Corporation for a minimum period of **120 days** from the date of opening of the Tender. Escalation in the rates (within the validity period) will not be entertained under any circumstances.

**16. OPENING AND EVALUATION OF THE TENDER**

16.1 The tenders received up to 11.00 AM as per the office clock on 03.11.2022 will be taken up for opening. Tenders received after specified date and time will not be accepted. The Tender will be opened in the presence of Managing Director of the Corporation or by the Person/Committee authorized by him / her at 11.30 AM on the same day in the presence of the available Tenderers/ representatives of the



	<p>Tenderers, who choose to be present. The Tenderers or their authorized agents are allowed to be present at the time of opening of the tenders.</p> <p>16.2 If the date fixed for opening of the tender happens to be a Government holiday, the sealed tenders will be received up to 11.00 AM on the next working day and opened at 11.30 AM on the same day.</p> <p>16.3 The Technical bid will be evaluated in terms of the qualification criteria by the Committee of Corporation. The Committee reserves the right to disqualify any of the tender, in case the Committee is not satisfied with the documents furnished, including the past performances.</p> <p>16.4 Any adverse/not satisfactory remarks on the performance of previous supplies made to the Corporation or to any other clients will entail disqualification of the tender without notice and price bids will not be opened.</p> <p>16.5 The Corporation reserves the right to inspect the manufacturing unit of the tenderer to verify the genuineness of the documents submitted by the tenderer.</p> <p>16.6 The tenderers declared as qualified by the Committee, will be informed the date of opening of Part-B (Price bid).</p>
17.	<b>SAMPLE EVALUATION</b>
	<p>17.1 The Tenderer while submitting the tender documents shall submit 3 untested samples of Geometry boxes and 3 samples of each mathematical drawing instrument, metal box and inner compartment without any markings/printings.</p> <p>17.2 The samples submitted by the tenderer shall be tested by the Corporation in a Government approved/NABL accredited testing laboratory. The testing of such samples shall be conducted to check whether the quality, size, specification, dimensions and measurement of the Geometry box and its contents (mathematical drawing instruments) are in conformity with the Technical specifications and other test parameters prescribed in the Tender document.</p> <p>17.3 The Corporation reserves the right to test the samples at its discretion and in the event of failure of the samples in the tests, the tender shall be summarily rejected.</p> <p>17.4 A substantially responsive tender is one which conforms to all the terms, conditions, and specifications of the tender document, without material deviation. A material deviation or reservation is one (a) which affects in any substantial way the scope, quality, or performance of the supply; (b) which limits in any substantial way, inconsistent with the tender documents, the Corporation's rights or the tenderer's obligations under the contract; or (c) whose rectification would affect unfairly the competitive position of other tenderers presenting substantially responsive bids.</p>

<b>18.</b>	<b>PRICE BID</b>
18.1	The Price bid should be kept only in the Part-B cover.
18.2	The date, time and venue of opening of Part-B Cover i.e. Price Bid will be intimated separately to the qualified eligible Tenderers.
18.3	The price bid should be prepared as per <b>Annexure - XVIII</b> .
18.4	GST should be quoted separately as per the price bid format.
18.5	The rate finalized for the award of contract shall be kept firm for a period of one year from the date of issue of Letter of Acceptance.
18.6	Any increase/decrease of GST during the period of Contract will be borne by the Corporation. Any increase in GST after the completion of Contract period, i.e. for the delayed supply, has to be borne by the tenderer.
18.7	The price should be neatly and legibly written both in figures and words.
18.8	In case of discrepancy between the prices quoted in words and figures, lower of the two shall be considered.
18.9	Part-B price bid should not contain any commercial conditions. Variation in the commercial terms and conditions of the tender will be summarily rejected.
<b>19.</b>	<b>EVALUATION OF THE PRICE BID &amp; ALLOCATION OF QUANTITY</b>
The price bid will be evaluated in accordance with Clause 31(4) of Tamil Nadu Transparency in Tenders Rules, 2000 and Amendments thereof as given below:	
19.1	The tenderer who has quoted the lowest price will be adjudged as L1.
19.2	The rates of L1 tenderer will be compared with the prevailing market rates and the rates of the previous period, and if the Corporation is of the view that the quoted rates are too high, it may negotiate with the Lowest Tenderer to ascertain whether further reduction in rates is possible.
19.3	The L1 tenderer will be allotted 60% of the tendered quantity, subject to the production capacity as assessed by Technical Committee appointed by the Corporation, and Bank's letter in support of Credit facility / Own funds equivalent to 25% of the value of the quantity considered for allotment.
19.4	The remaining quantity will be allotted to other qualified tenderers on ascending order of their price, at the price finalised for the L1 tenderer, subject to their

19.5	<p>production capacity as assessed by Technical Committee appointed by the Corporation, and Bank's letter in support of Credit facility / Own funds equivalent to 25% of the value of the quantity considered for allotment.</p> <p>The Tender Accepting Authority i.e. the Board of Governors of the Corporation reserves the right to accept or reject any or all of the tenders including the lowest in full or in part without assigning any reasons thereof and without thereby incurring any liability to the tenderer or tenderers who may be affected financially or otherwise to this effect.</p>
<b>20.</b>	<b>INCREASE OR DECREASE IN TENDERED QUANTITY</b>
<p>Quantity given in the Notice Inviting Tender is approximate and is likely to vary. As per Clause 14(9) of Tamilnadu Transparency in Tender Rules 2000, the Corporation, if necessary, at the time of placement of purchase order shall either increase or decrease the quantity finally ordered to the extent of 25% on the same terms and conditions.</p>	
<b>21.</b>	<b>LETTER OF ACCEPTANCE</b>
21.1	<p>The successful tenderers will be issued Letter of Acceptance (LOA) after obtaining approval from Board of Governors of the Corporation.</p>
21.2	<p>If at any time before the acceptance of tender, the Corporation receives information that a tenderer who has submitted tender has been banned by any Procuring Entity, the Corporation shall not accept the tender of that tenderer even if it may be the lowest tender.</p>
<b>22.</b>	<b>SECURITY DEPOSIT</b>
22.1	<p>On receipt of the Letter of Acceptance from Corporation, the successful tenderer(s) should remit a Security Deposit (SD) for a value equivalent to 5% of the value of allotted quantity in the form of Demand draft / Banker's cheque drawn on any Scheduled Commercial Bank in favour of the "Tamil Nadu Textbook and Educational Services Corporation, Chennai" or by an Irrevocable Bank Guarantee with a validity period of 18 months from any Indian Scheduled Commercial Bank, within 7 (Seven) working days from the date of receipt of letter of acceptance. The EMD shall be adjusted with the Security Deposit.</p>
22.2	<p>Any other amount pending with Corporation will not be adjusted under any circumstances, against the Security Deposit if so requested.</p>
22.3	<p>Security Deposit will be returned only after the completion of the Contract in full without any deficiency or default and to the entire satisfaction of the Corporation</p>

	<p>and on completion of the warranty period of 6 months post supply. The Security Deposit so held by the Corporation, shall not earn any interest till it is returned to the successful tenderer(s).</p> <p>22.4 In case of non-fulfilment of the contract and/or failure to supply the ordered quantity of Geometry boxes in full or part within the delivery period as per the terms and conditions stipulated in the tender, the Security Deposit will be forfeited.</p>
<b>23.</b>	<b>AGREEMENT</b>
23.1	The successful tenderer(s) should execute an Agreement on a ₹ 100/- non-judicial stamp paper within 7 working days from the date of issue of LOA and shall pay for all stamps and legal expenses incidental thereto. The Agreement format is given in <b>Annexure - XX</b> . In the event of failure to execute the Agreement within the time prescribed, the SD amount remitted by the successful tenderer will be forfeited besides cancellation of the Letter of Acceptance.
23.2	If the successful tenderer fails to execute the Agreement or fails to remit the security deposit within the specified time limit, the Corporation will blacklist the tenderer for a maximum period of 3 years in addition to forfeiture of EMD.
<b>24.</b>	<b>ISSUE OF PURCHASE ORDER</b>
	After furnishing the security deposit and execution of the agreement, Purchase Order will be issued indicating the quantity, points of delivery, schedule of supply, etc. The successful tenderer should supply ordered items as per the schedule given in Clause 27.1.
<b>25.</b>	<b>POINTS OF DELIVERY</b>
	The Geometry boxes are to be delivered at 534 delivery points indicated in the Purchase Order. The Corporation reserves its right to allot any delivery point in Tamil Nadu for operational convenience. The successful tenderer will not have any right to ask for change of delivery points.
<b>26.</b>	<b>EXTENSION OF VALIDITY PERIOD OF CONTRACT</b>
	The Tender Inviting Authority may extend the validity period of contract for further one year on the same terms & conditions.

<b>27.</b>	<b>SCHEDULE OF SUPPLY</b>
------------	---------------------------

27.1 The allotted quantity of Geometry boxes is to be delivered at the designated delivery points as per schedule below:

**T = Date of issue of Purchase Order**

Sl. No.	Milestone	Due date of Delivery (days)
1	25% of the ordered quantity	T + 30
2	50% of the ordered quantity	T + 45
3	75% of the ordered quantity	T + 60
4	100% of the ordered quantity	T + 75

27.2 The entire ordered quantity of Geometry boxes complying with the technical specifications mentioned in the Annexure I-A, I-B, I-C and I-D of the Tender Document shall be completed within 75 days from the date of issue of the Purchase Order.

27.3 The successful tenderer shall stick/print LOGO / TEXT etc. as per the instructions of Corporation on the items supplied.

27.4 The Geometry boxes shall be delivered to the designated locations of Block Educational Officers / District Educational Officers in the State of Tamil Nadu as per the Purchase Order in good condition. The Transit / Freight charges, Insurance, all the Taxes, Loading and Unloading charges and all other incidental charges for the supply and delivery of the ordered quantity of Geometry boxes in good condition to the designated locations shall be borne by the successful tenderer at his own risk and cost.

27.5 After delivery of the Geometry boxes at the designated delivery points, the successful tenderer shall obtain acknowledgement for proof of delivery of Geometry boxes in good condition from respective DEO/BEO for submission to the Corporation.

27.6 If there is a delay beyond 30 days with respect to the due date of delivery stated in Clause 27.1, the unsupplied quantity will be cancelled without any prior notice and allotted to the other suppliers. Notwithstanding the above, the Corporation has the right to permit the Manufacturer/Supplier beyond 30 days with penalty, in case of exigencies.

27.7 The Corporation reserves the right to purchase the unsupplied quantity arising due to cancellation/termination, from the open market. The consequential loss sustained by the Corporation to this effect shall be deducted from the bill of the

<p>Manufacturer/Supplier and / or from the Security Deposit without prior intimation.</p> <p>27.8 The Corporation shall have the right to terminate the contract of the successful tenderer who fails to deliver the Geometry boxes in full as per the purchase order and the delivery schedule.</p> <p>27.9 The Manufacturer/Supplier shall be disqualified in participating in future tender for the abnormal delay in supply, (i.e.) more than 90 days from the due date of supply for the forthcoming 1 year.</p>																
<b>28.</b>	<b>SUBMISSION OF DELIVERY PLAN</b>															
<p>28.1 The successful tenderer has to submit a supply schedule for delivery of ordered quantity as per Annexure - XXII within 5 days from the date of purchase order to the Corporation.</p> <p>28.2 The successful tenderer is required to submit weekly production plan by email to the Corporation on every Friday before 3 PM, starting from the date of commencement of regular production covering the following:</p> <table border="1" style="width: 100%; border-collapse: collapse;"> <tr> <td style="width: 5%; text-align: center;">(i)</td> <td style="width: 45%;">Raw material stock available in tenderer's warehouse</td> <td style="width: 50%;">Inventory breakup of each component &amp; mathematical instrument equivalent to _____ no. of Geometry boxes.</td> </tr> <tr> <td style="text-align: center;">(ii)</td> <td>Work in Progress</td> <td>_____ no. of Geometry boxes</td> </tr> <tr> <td style="text-align: center;">(iii)</td> <td>Finished products stock in the tenderer's warehouse</td> <td>_____ no. of Geometry boxes</td> </tr> <tr> <td style="text-align: center;">(iv)</td> <td>Quantity despatched</td> <td>_____ no. of Geometry boxes</td> </tr> <tr> <td style="text-align: center;">(v)</td> <td>Cumulative quantity despatched</td> <td>_____ no. of Geometry boxes</td> </tr> </table> <p>28.3 The Corporation reserves its right to physically verify the correctness of the particulars furnished by the tenderer. Any discrepancy will lead to reduction of allotted quantity.</p>		(i)	Raw material stock available in tenderer's warehouse	Inventory breakup of each component & mathematical instrument equivalent to _____ no. of Geometry boxes.	(ii)	Work in Progress	_____ no. of Geometry boxes	(iii)	Finished products stock in the tenderer's warehouse	_____ no. of Geometry boxes	(iv)	Quantity despatched	_____ no. of Geometry boxes	(v)	Cumulative quantity despatched	_____ no. of Geometry boxes
(i)	Raw material stock available in tenderer's warehouse	Inventory breakup of each component & mathematical instrument equivalent to _____ no. of Geometry boxes.														
(ii)	Work in Progress	_____ no. of Geometry boxes														
(iii)	Finished products stock in the tenderer's warehouse	_____ no. of Geometry boxes														
(iv)	Quantity despatched	_____ no. of Geometry boxes														
(v)	Cumulative quantity despatched	_____ no. of Geometry boxes														
<b>29.</b>	<b>PRE-DESPTACH INSPECTION</b>															
<p>29.1 Regular inspection and in-house tests shall be conducted on the compliance of specifications and quality parameters of the Geometry boxes while being manufactured at the premises of the Manufacturer's unit (or contract manufacturer's unit, in case of Supplier) by in-house QC personnel.</p> <p>29.2 10 samples from a lot of 10,000 Geometry boxes shall be taken at random by the QC personnel of the Manufacturer's unit (or contract manufacturer's unit, in case of Supplier) and out of which, one sample will be subjected to the in-house Lab Test at the premises of the manufacturing unit. If the sample fails in the tests, the</p>																

	<p>entire lot of 10,000 Geometry boxes has to be separated and moved out of the premises.</p> <p>29.3 The Manufacturer/Supplier is required to maintain proper record of all the in-house tests and shall submit weekly test record on every Monday before 3 PM by email to the Corporation, starting from the date of commencement of regular production.</p> <p>29.4 The Mathematical Drawing Instruments as specified in the Annexure I-A shall be kept in a Geometry Box. The QC cleared Geometry boxes are to be packed in non-hazardous pouches and 100 such Geometry boxes shall be packed in a corrugated box with sufficient buffer to avoid any damage during transit.</p>
<p><b>30.</b></p>	<p><b>POST-DELIVERY TESTING</b></p>
	<p>30.1 It shall be the responsibility of the Manufacturer/Supplier to ensure that the Geometry boxes are delivered in good condition complying with the specifications and quality parameters as mentioned in Annexure I-A, I-B, I-C and I-D.</p> <p>30.2 Post-delivery testing of the Geometry boxes will be carried out educational district wise.</p> <p>30.3 One sample for every 5,000 Geometry boxes and/or part thereof delivered at BEO/DEO offices of an education district, shall be drawn randomly by the officials of the educational department and sent to the Corporation in a sealed cover/box. The Corporation will send the sample to a Government approved/NABL accredited testing laboratory for testing.</p> <p>30.4 If the sample fails in the tests, the entire quantity of 5,000 Geometry boxes and/or part thereof attributable to the failed sample will be rejected. The Manufacturer/Supplier has to make fresh supply equivalent to the rejected quantity without any additional cost. Further, a penalty of 10% of the value of rejected quantity will also be levied by the Corporation. The rejected Geometry boxes will be withheld and returned to the Manufacturer/Supplier only after completing the entire ordered quantity.</p> <p>30.5 If the fresh supply for the rejected quantity of 5,000 Geometry boxes and/or part thereof is delivered beyond 75 days, the rejected quantity will not be returned to the Manufacturer/Supplier.</p> <p>30.6 If more than 10 sample boxes / 10% of the ordered quantity (whichever is higher) fail in the tests, in addition to imposing penalty, the tenderer will be blacklisted for the forthcoming 1 (one) year.</p> <p>30.7 The charges including the testing charges, freight charges, travelling expenses and other incidental expenses shall be borne by the Manufacturer/Supplier.</p>

<b>31.</b>	<b>PACKING AND LABELLING</b>
31.1	The Mathematical Drawing Instruments as specified in the Annexure I-A, I-B and I-C shall be kept inside a Geometry Box. Each Geometry box shall be packed in a non-hazardous pouch of appropriate size.
31.2	100 Geometry boxes packed in non-hazardous pouches shall be placed in a corrugated box with sufficient buffer to avoid any damage during transit. The corrugated box shall be made from Kraft paper of 150 GSM, 5 Ply and Burst Factor of 14.
31.3	Each corrugated box shall be labelled and the label shall contain the following: NOT FOR SALE, SCHEME OF SUPPLY OF COST-FREE GEOMETRY BOX TO SCHOOL CHILDREN by the Department of School Education, Government of Tamil Nadu, Manufacturer/Supplier code no., District code, Block code, Serial number, Box number, Date, Month and Year of manufacturing of the Geometry box and quantity of Geometry boxes. The Corporation will provide the format of the label at the time of Purchase Order.
<b>32.</b>	<b>INSURANCE</b>
The delivery of the quality tested Geometry boxes in fully packed and labelled condition as per the statutory norms and the specifications given in the Tender Document to the designated delivery points in time shall be the responsibility of the Manufacturer/Supplier. The transit loss / theft / pilferage / damage of the Geometry boxes under any circumstance shall be the liability of the Manufacturer/Supplier. Insurance and transit insurance of the Geometry box shall be the liability of the Manufacturer/Supplier.	
<b>33.</b>	<b>WARRANTY AND REPLACEMENT</b>
33.1	The warranty of the Geometry box supplied by the Manufacturer/Supplier shall be for a period of six months from the date of distribution of the same to the school children in each block in each District in Tamil Nadu. The Manufacturer/Supplier shall replace the defective Geometry boxes with new ones at his cost at the designated points during the period of Warranty.
33.2	Defective Geometry boxes, if any, indicated in the feedback form obtained from beneficiary students through the respective DEOs / BEOs shall be replaced with new Geometry boxes at the designated delivery points at his cost.



<b>34.</b>	<b>PAYMENT TERMS</b>
<p>34.1 No advance payment is permissible.</p> <p>34.2 Payment will be processed after satisfactory delivery of entire quantity of Geometry boxes to the designated delivery points at the BEO/DEO in a district.</p> <p>34.3 The delivery reports along with delivery challans signed by the concerned Block Educational Officers / District Educational Officers with acknowledgement duly affixed with proper seal are to be submitted to the Corporation.</p> <p>34.4 Based on the acknowledgements issued by the Block Educational Officers / District Educational Officers, the bills will be admitted and processed. 80% of the bill value will be paid ordinarily in 30 days after post-test clearance report.</p> <p>34.5 Out of the remaining 20% of the billed amount, 15% shall be paid after satisfactory feedback from schools on the quality of the Geometry boxes, duly deducting penalty (if any), testing charges and other incidental charges.</p> <p>34.6 The remaining 5% of the billed amount shall be paid after the completion of 6 months' warranty period.</p> <p>34.7 All payments under this Contract shall be made to the Bank Account of the Successful tenderer.</p> <p>34.8 The Corporation reserves the right to recover any dues from the Manufacturer/ Supplier, which is found on later date, during audit/excess payment, after final settlement is made to them. The tenderer is liable to pay such dues to the Corporation immediately on demand, without raising any dispute/protest.</p> <p>34.9 The bill raised by the Successful Tenderer shall have all Registration Numbers (GST/TAN/CIN) printed on the Bill. The validity of the Tax Registration during the currency period of the Contract shall be the sole responsibility of the Successful Tenderer.</p>	
<b>35.</b>	<b>PENALTY</b>
<p>35.1 If the successful tenderer fails to deliver 50% of the ordered quantity within the due date specified in Schedule of Supply (Clause 27.1), the Corporation shall have the right to impose <b>penalty of 1%</b> of the value of the delayed supply with applicable GST (which includes the date of replacement of defective Geometry box) for every week of delay or part thereof after the due date of delivery for a period of <b>Two weeks</b> and thereafter at the rate of <b>3%</b> of the value of the delayed</p>	

	<p>supply with applicable GST for each Week of delay or part till completion. Maximum penalty shall be limited to 10% of the total contract value.</p> <p>35.2 The Corporation reserves the right to purchase the unsupplied quantity arising due to cancellation/termination, from the open market. The consequential loss sustained by the Corporation to this effect shall be deducted from the bill of the Manufacturer/Supplier and / or from the Security Deposit without prior intimation.</p> <p>35.3 In respect of replacement of Geometry boxes, the date of replacement will be taken as actual date of supply. In such cases, the ordered quantity of Geometry boxes for that location where the replacement was made will be taken for calculation of delay penalty. Total number of days for delay penalty will be reckoned as under:</p> <p>(i) No. of days for delay penalty as per Clause 35.1</p> <p>(ii) No. of days from the date of intimation of rejection to the date of delivery of fresh supply for the rejected quantity</p> <p>(iii) Total number of days for delay penalty = (i) + (ii)</p> <p>35.4 If the Geometry boxes supplied are found to be inferior in quality with respect to pre-approved specifications, there shall be replacement of the entire lot and/or a fine up to 10% of the defective lot.</p>
36.	<b>LIQUIDATED DAMAGES</b>
36.1	<p>The successful tenderer shall not manufacture, market, sell or supply the Geometry boxes manufactured, packed and labelled as per the Technical specifications in the Tender Document exclusively for distribution among the School Children studying in Government and Aided schools in Tamil Nadu. The Corporation shall impose penalty of not less than ₹ 5,00,000/- (Rupees Five Lakh Only) every time for violation of the aforesaid condition. The penalty shall be in addition to the Civil and Criminal action taken by the Corporation against such successful tenderer(s) in default.</p>
36.2	<p>The Corporation shall have the right to blacklist such successful tenderer(s) from participating in the subsequent Tenders of the Corporation for a minimum period of five years.</p>
37.	<b>CORRUPT OR FRAUDULENT PRACTICES</b>
37.1	<p>The Tenderers shall observe the highest standard of ethics during tender evaluation and supply of Geometry box. In order to eliminate irregularities, interference and corrupt practices in tender process by providing transparency in such matters, the</p>

Corporation defines the following terms:

- 37.1.1 'Corrupt practice' means offering, giving, receiving or soliciting of anything of value to influence the action of a public official in the evaluation process or in contract execution.
- 37.1.2 'Fraudulent practices' mean a misrepresentation of facts in order to influence the evaluation process or execution of a contract / supply to the detriment of the Corporation and includes collusive practice among tenderers (prior to or after Tender submission) designed to establish bid prices at artificial, non-competitive levels and to deprive the Corporation of the benefits of free and open competition.
- 37.2 The Corporation will reject a tender if it decides that the Tenderer recommended for the award has engaged in corrupt or fraudulent practices in competing for the tender.
- 37.3 The Corporation will declare a tenderer ineligible either indefinitely or for a stated period of time to be awarded a contract, if it any time determines that the tenderer has engaged in corrupt and fraudulent practices in competing for the tender or in executing the contract.

**38.**

**TERMINATION OF CONTRACT**

- 38.1 The Corporation reserves the right to terminate the contract at any time during the validity period on account of non-fulfilment of contract or any of the reasons.
- 38.2 Termination for Default:**
- 38.2.1 If the delay continues beyond 50% of the original supply period, the contract is liable to be terminated at the discretion of the Corporation.
- 38.2.2 If the Successful Tenderer is found to have involved in fraudulent, corrupt and unfair practices in competing for or in executing the Contract;
- 38.2.3 If the Corporation terminates the Contract in whole or in part, the Corporation may procure, upon such terms and in such manner as it deems appropriate, the Geometry box similar to those supplied and delivered and in that case, the Successful Tenderer whose contract is terminated in whole or in part shall be liable to the Corporation for any additional costs involved in procuring and supplying the Geometry box to the designated destinations. However, the Successful Tenderer shall continue the performance of the Contract to the extent not terminated. The Corporation reserves the right to take further action against the Successful Tenderer whose Contract has been terminated in whole or in part.

**38.3 Termination for Insolvency:**

38.3.1 The Corporation may at any time terminate the Contract by giving 15 days' written notice to the Successful Tenderer without compensation to the Successful Tenderer and without incurring any liability if the Successful Tenderer becomes bankrupt or otherwise insolvent. Such termination shall not prejudice or affect any right of action or remedy that has accrued or will accrue thereafter to the Corporation.

**38.4 Termination for Convenience:**

38.4.1 The Corporation may terminate the Contract in whole or in part at any time during the validity period of the Contract for its convenience by giving 15 days' written notice and without compensation to the Successful Tenderer. The notice of termination shall specify that termination is for the Corporation's convenience, the extent to which the Contract is terminated, and the date upon which such termination becomes effective. The termination of the contract is without prejudice to the penal consequences and damages for which the Successful Tenderer shall be liable for violation of the Contractual obligations.

**39.****BLACKLISTING**

39.1 If the tenderer has submitted forged documents in this tender or if any information provided by the tenderer is found to be false/fictitious in any tender of the Government, the tenderer will be blacklisted for a period of 5 years.

39.2 If the successful tenderer fails to execute the Agreement or fails to remit the security deposit within the specified time limit, the Corporation will blacklist the tenderer for a maximum period of 3 years in addition to forfeiture of EMD.

39.3 In the event of non-performance of the contractual provisions or failure to effect the supply within the stipulated time or during the extended period, and if it is found that the contractor has not fulfilled the contractual obligation with the Corporation in any manner during the currency of the contract or also found on later date, the Corporation reserves the right to disqualify such successful tenderer to participate in future tenders or blacklist the tenderer up to a maximum period of 5 years.

39.4 Termination / full or partial cancellation of the supply of Geometry boxes to the Corporation will entail blacklisting of the Manufacturer/Supplier for a maximum period of 5 years.

39.5 If more than 10 sample boxes / 10% of the ordered quantity (whichever is higher) fail in the tests, in addition to imposing penalty, the Manufacturer/Supplier will be

	<p>blacklisted for the forthcoming 1 (one) year.</p> <p>39.6 If the successful tenderer is found to have involved in fraudulent, corrupt and unfair practices in competing for or in executing the contract the Corporation will blacklist the tenderer for a period of 5 years.</p> <p>39.7 The Corporation shall have the right to blacklist the Manufacturers/Suppliers who are levied liquidated damages as per Clause 36, for a period of 5 years.</p> <p>39.8 The Corporation shall have the right to blacklist the successful tenderer for breach of any Terms and Conditions of the Tender / Agreement at any point of time.</p>
<b>40.</b>	<b>FORCE MAJEURE</b>
	<p>40.1 Force Majeure means an event beyond the control of the successful tenderer and not involving the successful tenderer's fault of negligence and not foreseeable. Such event may include but are not limited to the acts of Nature such as fire, floods, epidemics, etc. and other events such as wars, revolutions, quarantine restrictions, etc.</p> <p>40.2 If a Force Majeure situation arises, the successful tenderer shall promptly notify the Corporation of such conditions and the causes thereof through e-mail within 24 hours of such event. The e-mail communication shall be followed by a report with documentary evidence to be sent to the Corporation within 3 days from the date of occurrence of such event. Unless otherwise directed by the Corporation in writing, the successful tenderer shall continue to perform his obligations under the Contract to a reasonably practical extent and shall seek all reasonable alternative means for effective performance of the Contract in time.</p> <p>40.3 In the event of Force Majeure, the delivery period will be extended for a period equivalent to the period during which Force Majeure event was in existence. For this period, the successful tenderer shall not be liable to pay penalty. Further if the performance in whole or part, of any obligation under this Contract is prevented or delayed by reason of Force Majeure for a period exceeding 21 days, the Corporation may at its option and discretion terminate the Contract.</p>
<b>41.</b>	<b>GENERAL CONDITIONS</b>
	<p>41.1 Conditional tender in any form will not be accepted.</p> <p>41.2 Corporation reserves the right to relax or waive or amend any of the tender conditions.</p>

- 41.3 The right of final acceptance of the tender is entirely vested with the Corporation and the Corporation reserves the right to accept or reject any or all the tenderers in part or in totality or to negotiate with any or all the tenderers or to withdraw/ cancel/ modify this tender without assigning any reason whatsoever.
- 41.4 The successful tenderer shall not offload either full or part of the work to any other tenderer.
- 41.5 Any notice regarding any problems, to the tenderer shall deemed to be sufficiently served, if given in writing by email and/or communication sent to his usual or last known place of business.
- 41.6 If any discrepancy was found in the tenderer's documents provided in support of qualification criteria at a later date, the Corporation has the right to cancel the order and forfeit the EMD and Security Deposit of the tenderer.

**42.****DISPUTE RESOLUTION BOARD**

A Dispute Resolution Board (DRB) shall be formed in order to resolve the disputes that may arise during the currency of the contract. The members of the DRB shall be nominated by the Corporation and the successful tenderer. If any party is not satisfied with the decision of the DRB, the issue shall be referred for Arbitration.

**43.****ARBITRATION**

- 43.1 The issues not resolved by DRB shall be referred for Arbitration and same shall be dealt in accordance with the Indian Arbitration and Conciliation Act, 1996 and Rules of Indian Council of Arbitration. The Arbitrator shall be selected by the successful tenderer from the panel of Arbitrators approved by the Corporation within 15 days from the date of receipt of the letter from the Corporation along with the panel. If there is no reply from the tenderer within 15 days, the Corporation shall choose any of the Arbitrators from the panel of Arbitrators referred to above. The remuneration for the Arbitrator and other expenses shall be shared equally by the Corporation and the tenderer.
- 43.2 The venue of the Arbitration shall be at the Head office of the Corporation in Chennai. The decision of the Arbitrator shall be final and binding on both the parties to the Arbitration. The language of arbitration proceedings shall be in English.
- 43.3 The Arbitrator may with the mutual consent of the parties, extend the time for making the award. The award to be passed by the Arbitrator is enforceable in the Courts at Chennai city only.

44.	<b>JURISDICTION OF THE COURT</b>
<p>44.1 The courts in the city of Chennai exclusively shall have the jurisdiction to try any matter or dispute or reference between the Corporation and the Successful Tenderers arising out of the Contract.</p> <p>44.2 The Successful Tenderer is required to submit an undertaking towards jurisdiction of legal proceedings in the format enclosed in <b>ANNEXURE - XXIII</b>.</p>	
<p>We agree to the above terms and conditions.</p> <p><b>SIGNATURE OF THE TENDERER:</b></p> <p><b>DATE:</b></p> <p><b>NAME IN BLOCK LETTERS:</b></p> <p><b>DESIGNATION:</b></p> <p><b>ADDRESS:</b></p>	

**ANNEXURE I-A****TECHNICAL SPECIFICATIONS FOR GEOMETRY BOX****Specifications of Geometry Boxes & Mathematical Drawing Instruments****A. Geometry Box**

1. Thickness of the sheet used for Geometry Boxes (Mathematical Drawing Instruments) should be  $0.22 \pm 0.01$  mm and made out of Tin-free Mild steel (Press Metal Sheet with varnish coated).
2. The corners should be curved and the edges of both bottoms and top should be rolled so that there are no sharp corners.
3. The box should have double lock.
4. Box Length  $181 \pm 5$  mm, Breadth  $75 \pm 3$  mm, Height  $18 \pm 2$  mm
5. The top of the Box should be printed with Tamil Nadu Logo with non-toxic polyester ink. Then it should be glazed with non-toxic material. It should have scratch guard.
6. Box should have inner compartments for separating and protecting the components from damages and made out of High Impact Polystyrene.
  - Compartment Size:  $175 \times 70 \times 12$  mm (with  $\pm 1$  mm tolerance),
  - Thickness:  $0.45 \text{ mm} \pm 0.05 \text{ mm}$
7. Inside of the top lid should be printed with Tables of Metric Equivalence and Apollonius and Pythagoras Theorem.

**B. Mathematical Instruments**

Sl. No.	Name of the Instrument	Usage	Technical Specification
1	Scale	To measure 6 Inches Scale leaving 3 mm white space at both ends	Should be made of high quality general purpose polystyrene, virgin and clear grade.
2	Protractor	180 degree to measure and draw angles	Should be made of high quality General purpose polystyrene, virgin and clear grade.
3	Set-square - Two types	45 degree and 30 degree to 60 degree set-square - to measure small segments also for Drawing perpendicular and parallel lines	Should be made of high quality general purpose polystyrene, virgin and clear grade.



Sl. No.	Name of the Instrument	Usage	Technical Specification
4	Compass- 11.5 cm	To draw a circle and also draw angle	Compass should be made of rust resistant high quality MS Sheet and coated with rust resistant materials (Plated Metal) and the pencil holder with check nut should be made out of ABS Material. Hinge head should be made out of polypropylene and also the compass pointer should have plastic needle cap for protection.
5	Divider- 11.5 cm	To measure a distance between 2 points	Divider should be made out of rust resistant, high quality and plated M.S. Sheet and hinge head should be made out of polypropylene and also the both pointer should have plastic needle cap for protection.
6	Pencil	Length : min. 90 mm $\pm$ 2mm	Half HB Pencil hexagonal shape with High quality carbon / lead point. The pencil should be non-toxic
7	Sharpener	Length 29 mm with Metal Blade fixed properly with Metal Screw	Body of the sharpener should be made of high quality polystyrene and the blade should be made of high speed carbon steel with rust resistant coating.
8	Eraser	28 x 14 x 9 mm	Eraser should be made of non- toxic plasticized PVC rubber material.

**Note:** The measurement should be embossed and printed legibly as per the specifications and dimensions in the drawing enclosed.

**SIGNATURE OF THE TENDERER  
(with seal)**

DRAWINGS

MODEL OF GEOMETRY BOX

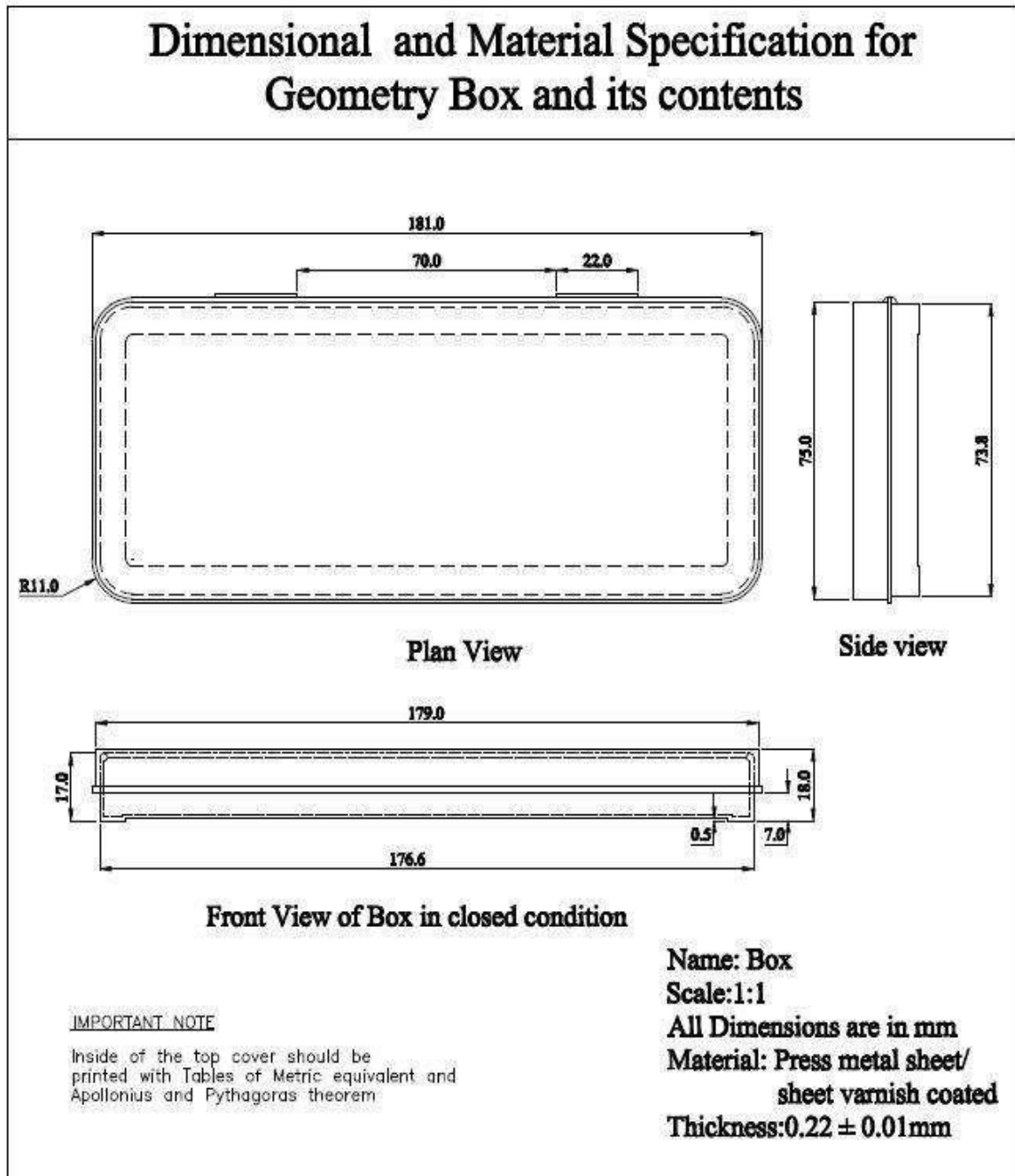

SIGNATURE OF THE TENDERER  
(with seal)

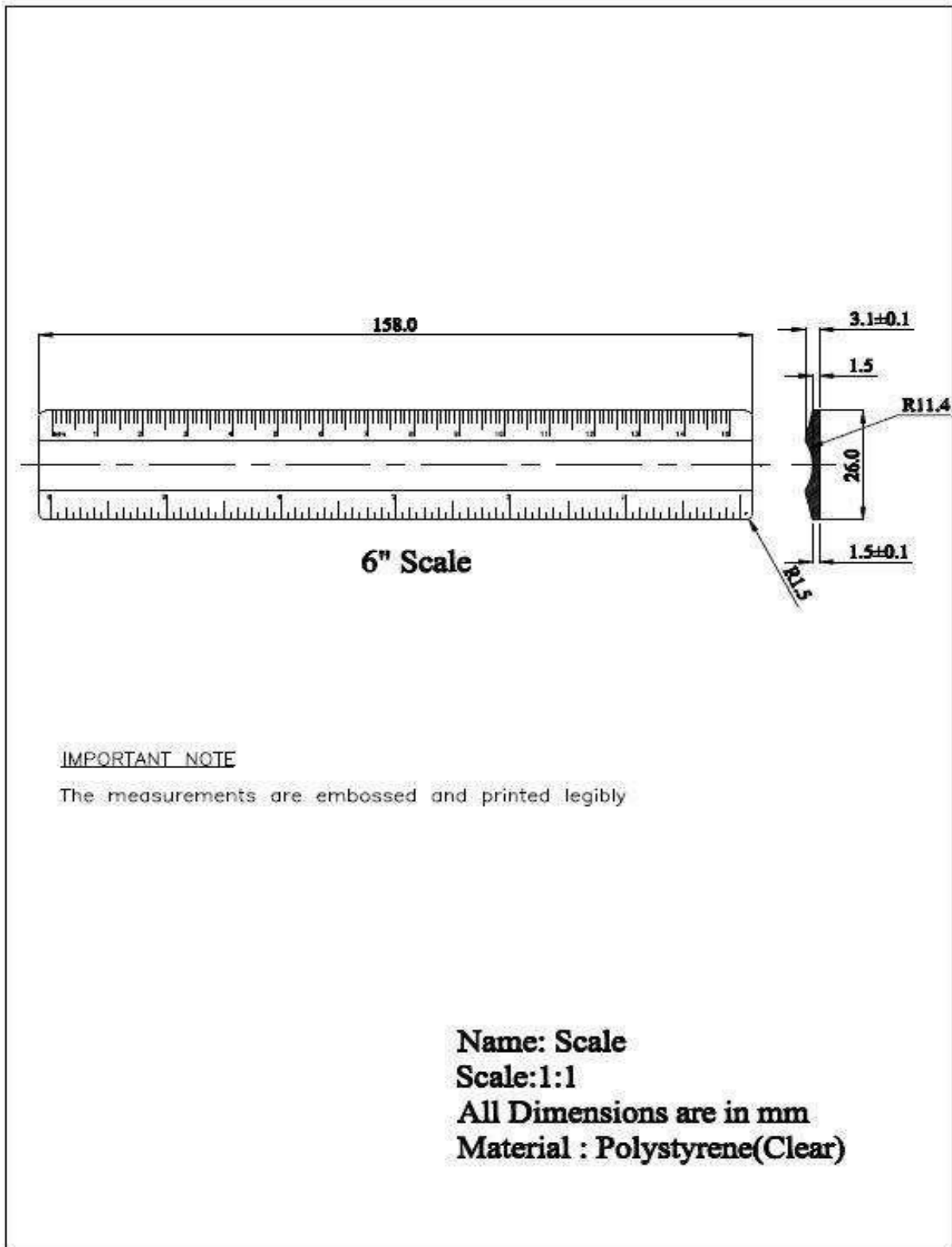

SIGNATURE OF THE TENDERER  
(with seal)

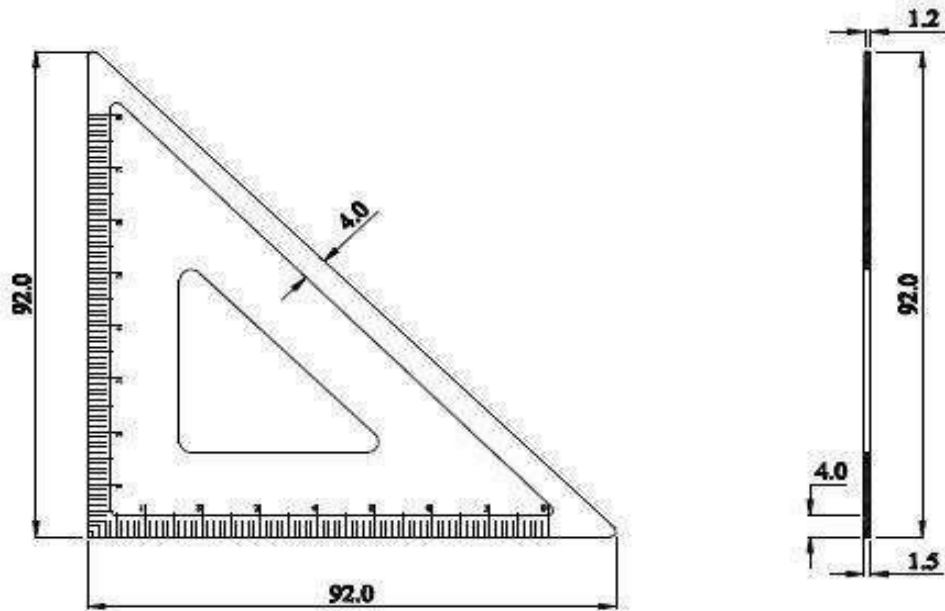

**45° Set square**

**IMPORTANT NOTE**

The measurements are embossed and printed legibly

**Name: 45° Set square**

**Scale: 1:1**

**All Dimensions are in mm**

**Material : Polystyrene (Clear)**

**SIGNATURE OF THE TENDERER  
(with seal)**

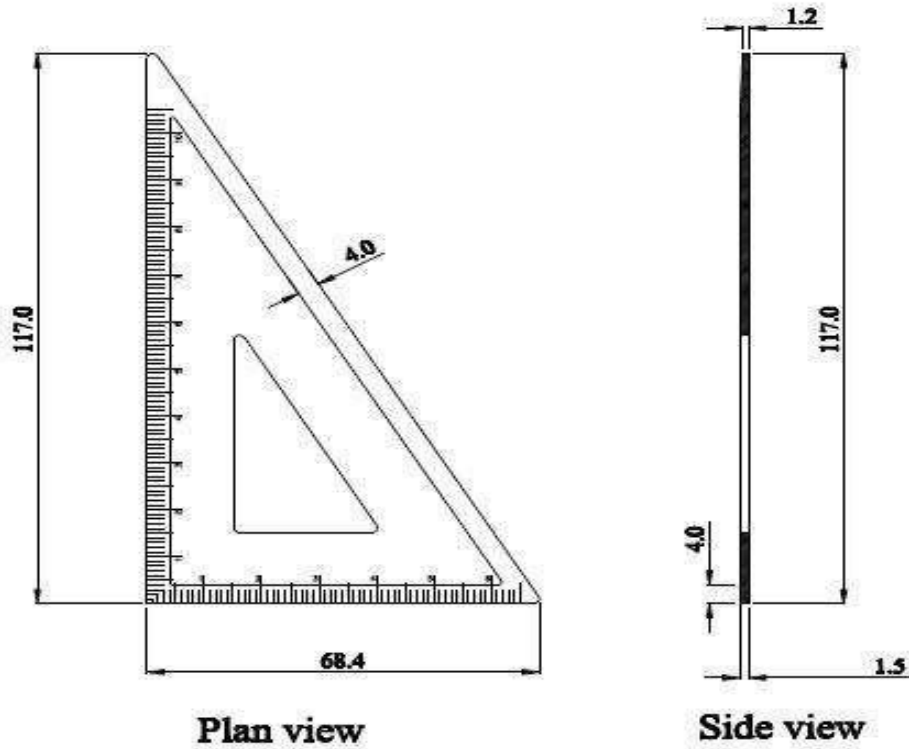

IMPORTANT NOTE

The measurements are embossed and printed legibly

**Name: 30° - 60° Set square**  
**Scale: 1:1**  
**All Dimensions are in mm**  
**Material : Polystyrene (Clear)**

**SIGNATURE OF THE TENDERER**  
**(with seal)**

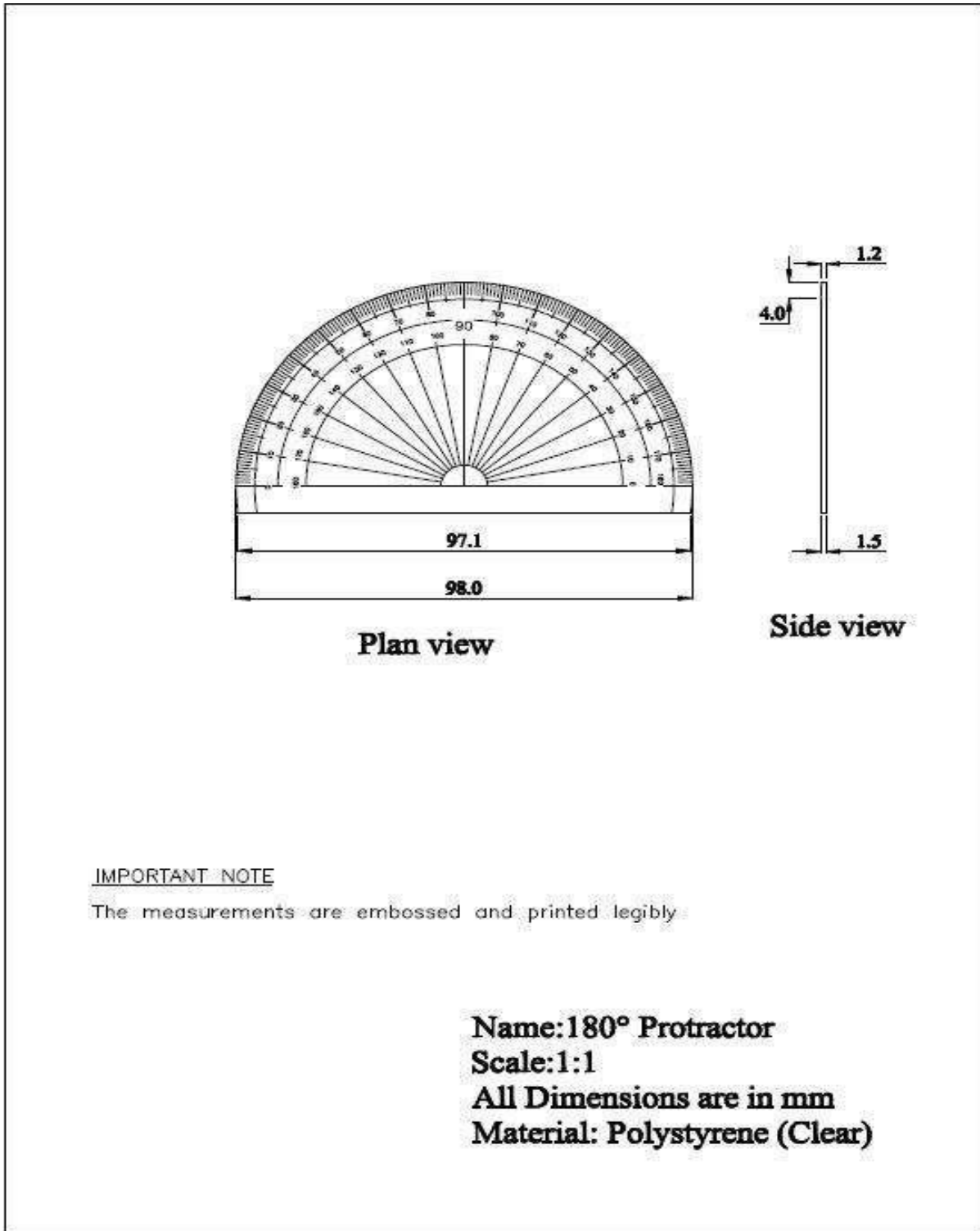

SIGNATURE OF THE TENDERER  
(with seal)

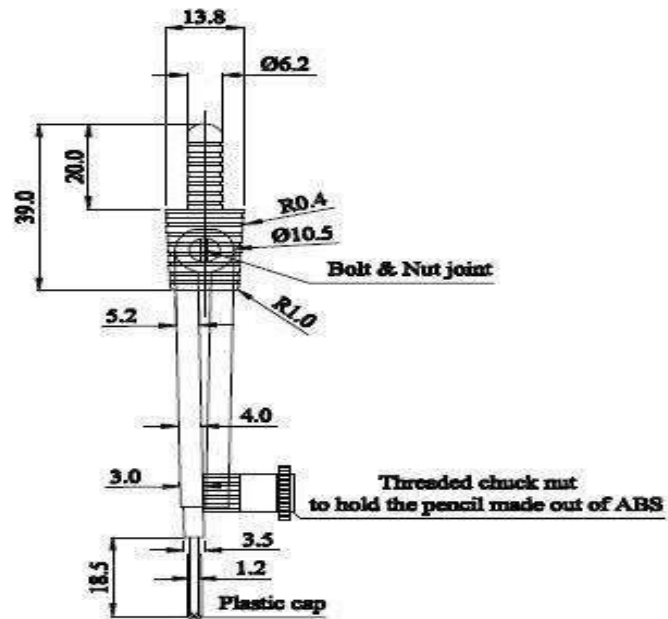

Pencil length :  $90 \pm 2$  mm

Hinge head and pencil holder details in separate sheet

Name: Compass,  
Scale:1:1  
All Dimensions are in mm  
Material: Plated metal  
Minimum dimensions requirements as given in the figure

SIGNATURE OF THE TENDERER  
(with seal)

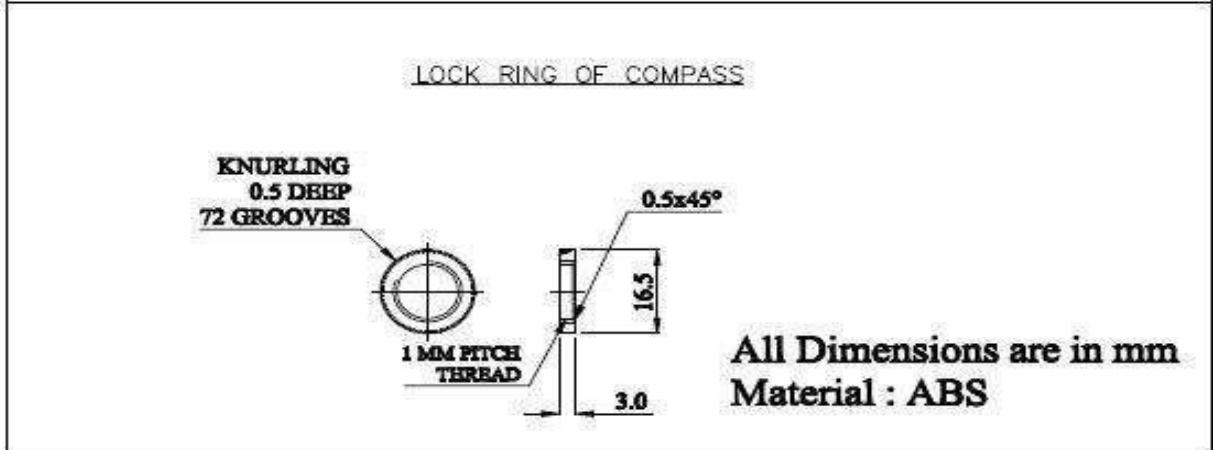
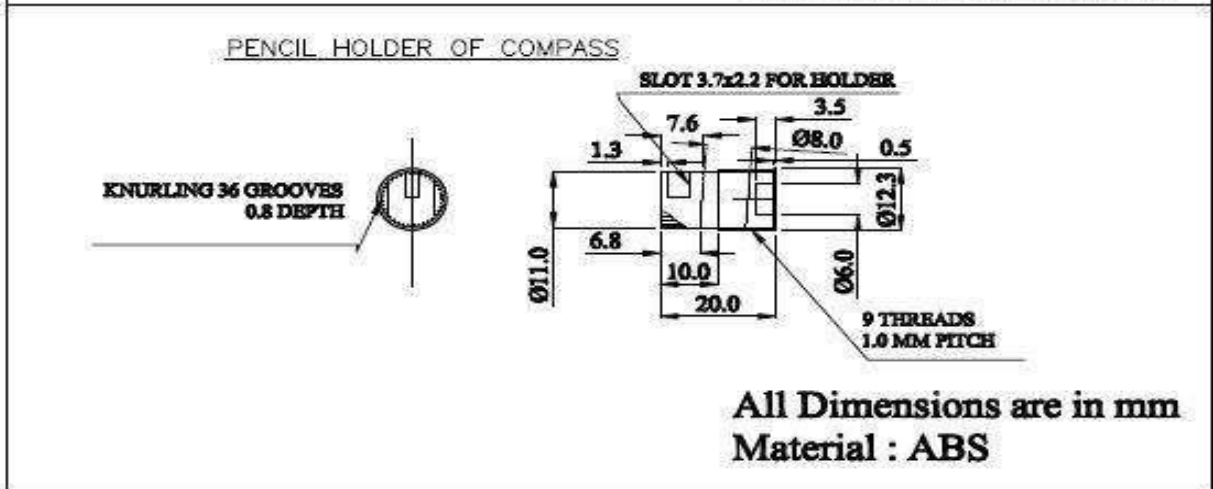
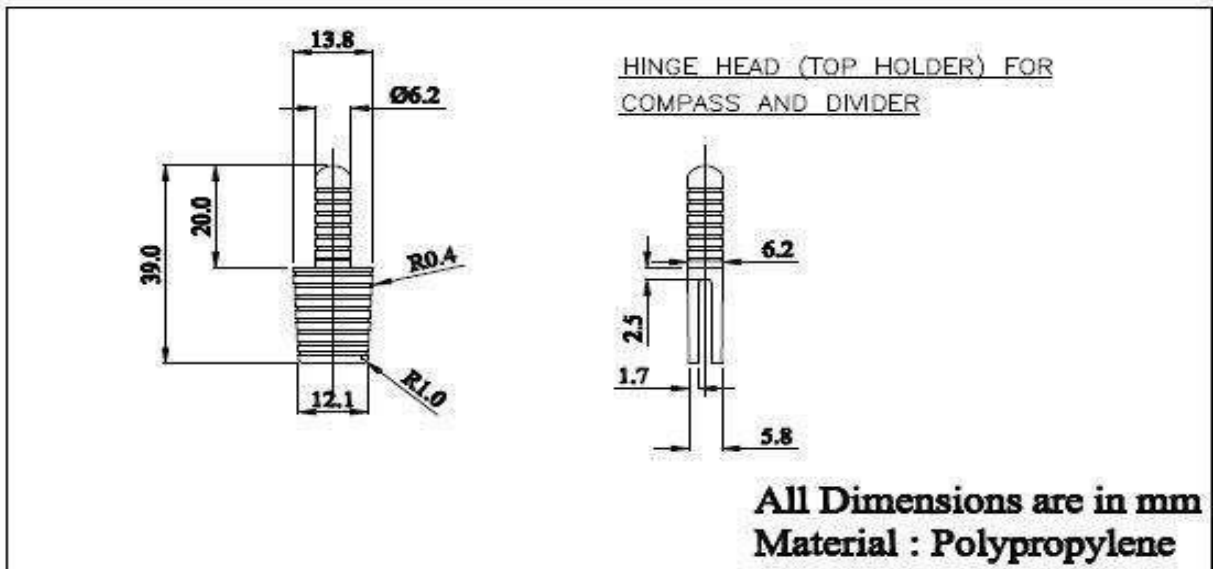

SIGNATURE OF THE TENDERER  
(with seal)



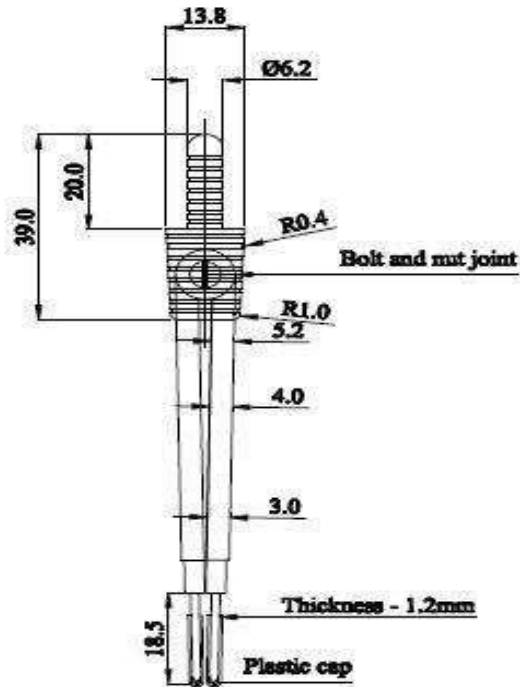

**Divider**

**Name: Divider**

**Scale: 1:1**

**All Dimensions are in mm**

**Material: Plated Galvanized metal**

**Minimum dimensional requirements as given in the figure**

**SIGNATURE OF THE TENDERER  
(with seal)**

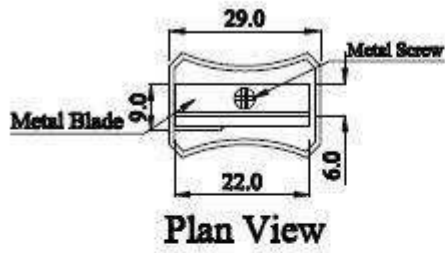

**Plan View**

**Side View**

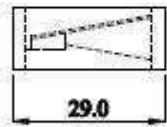

**Front view**

**Name: Sharpener**

**Scale: 1:1**

**All Dimensions are in mm**

**Material: Polystyrene (Clear)**

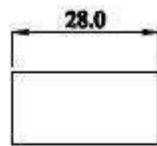

**Plain View**

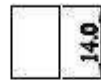

**Side View**



**Front view**

**Name: Eraser**

**Scale: 1:1**

**All Dimensions are in mm**

**Material: Plasticised PVC**

**ANNEXURE I-C**

**RAW MATERIALS**

**Details of raw materials used in manufacturing of Geometry boxes**

Sl. No.	Name of the Instrument	Technical Specification	Quantity of samples
1	Scale	Should be made of high quality general purpose polystyrene, virgin and clear grade.	3 Nos.
2	Protractor	Should be made of high quality General purpose polystyrene, virgin and clear grade.	3 Nos.
3	Set-square - Two types	Should be made of high quality general purpose polystyrene, virgin and clear grade.	3 Nos.
4	Compass- 11.5 cm	Compass should be made of rust resistant high quality MS Sheet and coated with rust resistant materials (Plated Metal) and the pencil holder with check nut should be made out of ABS Material. Hinge head should be made out of polypropylene and also the compass pointer should have plastic needle cap for protection.	3 Nos.
5	Divider- 11.5 cm	Divider should be made out of rust resistant, high quality and plated M.S. Sheet and hinge head should be made out of polypropylene and also the both pointer should have plastic needle cap for protection.	3 Nos.
6	Pencil	Half HB Pencil hexagonal shape with High quality carbon / lead point. The pencil should be non-toxic	3 Nos.
7	Sharpener	Body of the sharpener should be made of high quality polystyrene and the blade should be made of high speed carbon steel with rust resistant coating.	3 Nos.
8	Eraser	Eraser should be made of non-toxic plasticized PVC rubber material.	3 Nos.
9	Box	Thickness of the sheet used for Geometry Box should be $0.22 \pm 0.01$ mm and made out of Tin-free Mild steel (Press Metal Sheet with varnish coated). The box should have double lock.	3 Nos.
10	Inner compartment	Box should have inner compartments made out of High Impact Polystyrene	3 Nos.

**SIGNATURE OF THE TENDERER  
(with seal)**

## ANNEXURE I-D

## TESTING PROCEDURES

## A. Material Specification and Testing Method for Protractor, Set square and Scale

Sl. No	Description	Test Method	Unit	Scale	Protractor	Set Square	Pencil Sharpener Body	Eraser
1.	Material	--	--	General Purpose Polystyrene clear grade	General Purpose Polystyrene clear grade	General Purpose Polystyrene clear grade	General Purpose Polystyrene coloured grade	Plasticized PVC (white)
2.	Density	ASTM D 792	g/cc	1.04 ± 0.02	1.04 ± 0.02	1.04 ± 0.02	1.04 ± 0.02	1.960
3.	Hardness (Shore A)	ASTM D 2240	--	--	--	--	--	60.0 ± 5.0

## B. Material Specification and Testing Method for Compass and Divider

Sl.No	Description	Test Method	Unit	Compass	Divider
1.	Material	IS:3203	---	Rust resistant, high quality plated M.S. Sheet	Rust resistant, high quality plated M.S. Sheet
	(i) Plating Material			Nickel	Nickel
	(ii) Plating Thickness min.		Micron	4.0	4.0

## C. Material Specification and Testing Method for Pencil Holder for Compass &amp; Hinge Head of Compass and Divider

Sl. No.	Description	Test Method	Unit	Colour	Pencil Holder	Compass Hinge Head	Divider Hinge Head
1.	Material	--	--	Maroon	ABS	Virgin Polypropylene	Virgin Polypropylene
2.	Density	ASTM D-792		Maroon	1.11 - 1.12	0.891 - 0.910	0.891 - 0.910

**Note:** The hinge head of the compass and divider should be subject to appropriate flexing test to ensure lasting quality.

SIGNATURE OF THE TENDERER  
(with seal)

## Testing Procedure for Plastics - ASTM D792-2020 (Density of Plastics)

### Scope

These test methods describe the determination of the specific gravity (relative density) and density of solid plastics.

### Test Method A - For testing solid plastics in water

This test method involves weighing a one-piece specimen of 1 to 50 g in water, using a sinker with plastics that are lighter than water. This test method is suitable for plastics that are wet by, but otherwise not affected by water.

### Summary of Test Method

Determine the mass of a specimen of the solid plastic in air. It is then immersed in a liquid, its apparent mass upon immersion is determined, and its specific gravity (relative density) calculated

### Apparatus

1. *Analytical Balance*—A balance with a precision of 0.1 mg or better is required for materials having densities less than 1.00 g/cm<sup>3</sup> and sample weights less than 10 grams.
2. *Sample Holder*, corrosion-resistant (for example, wire, gemholder, etc.).
3. *Sinker*—A sinker for use with specimens of plastics that have specific gravities less than 1.00. The sinker shall have an opening to facilitate attachment to the specimen and sample holder.
4. *Immersion Vessel*—A beaker or other wide-mouthed vessel for holding the water and immersed specimen.
5. *Thermometer*—A thermometer readable to 0.1 °C or better

### Procedure

1. For density calculation, measure and record the water temperature.
2. Weigh the specimen in air. Weigh to the nearest 0.1 mg for specimens of mass 1 to 10 g and density less than 1.00 g/cm<sup>3</sup>. Weigh to the nearest 1 mg for other specimens.
3. If necessary, attach to the balance a piece of fine wire sufficiently long to reach from the hook above the pan to the support for the immersion vessel. In this case, attach

the specimen to the wire such that it is suspended about 25 mm above the vessel support.

4. If a wire is used, weigh the specimen in air after hanging from the wire. In this case, record the mass of the specimen,  $a = (\text{mass of specimen} + \text{wire, in air}) - (\text{mass of wire in air})$ .
5. Mount the immersion vessel on the support, and completely immerse the suspended specimen (and sinkers, if used) in water at a temperature of  $23 \pm 2^\circ\text{C}$ .
6. Determine the mass of the suspended specimen to the required precision. Record this apparent mass as  $b$  (the mass of the specimen, sinker, if used, and the partially immersed wire in liquid). Unless otherwise specified, weigh rapidly in order to minimize absorption of water by the specimen.
7. Weigh the sample holder (and sinker, if used) in water with immersion to the same depth as used in the previous step. Record this weight as  $w$  (mass of the sample holder in liquid).

8. Calculate the specific gravity of the plastic as follows:

$\text{sp gr}^{23/23^\circ\text{C}} = a / (a + w - b)$ , where:

$a$  = apparent mass of specimen, without wire or sinker, in air,

$b$  = apparent mass of specimen (and of sinker, if used) completely immersed and of the wire partially immersed in liquid, and

$w$  = apparent mass of totally immersed sinker (if used) and of partially immersed wire.

9. Calculate the density of the plastic as follows:

$D^{23^\circ\text{C}}, \text{ kg/m}^3 = \text{sp gr}^{23/23^\circ\text{C}} \times 997.5$

**LETTER OF THE TENDERER**

To  
The Managing Director  
Tamil Nadu Textbook and Educational Services Corporation,  
EVK SAMPATH MAALIGAI, D.P.I. Campus, 68, College Road,  
Chennai-600 006. Tamil Nadu.

Sir,

I / We do hereby tender / offer to the Tamil Nadu Textbook and Educational Services Corporation for the “**Supply and delivery of Geometry box**” conforming to the technical specifications and to the conditions stated in the annexed contract and specification and drawings attached here to.

I / We have carefully understood the conditions of tender, details of the materials to be supplied and the specifications and drawings with all the stipulations to which I / We agree to comply.

I / We hereby undertake to complete the delivery of Geometry box at the designated places mentioned in the contract, within the time limit as specified by the Corporation.

I am / We are quite aware that quality of the materials and time of delivery are the essence of this contract and accordingly, I / we would adhere to the same.

I / We further agree that I / We would not withdraw this tender either in full or in part. If by chance, I / we have to withdraw the offer, I / we agree that the EMD paid will be forfeited by the Corporation, without any notice to me / us.

I / We affirm that in any previous tender to the Tamil Nadu Textbook and Educational Services Corporation, I / we have not committed any fraud by furnishing wrong information and the Corporation had not written to us alleging fraud in our transaction with the Corporation.

I / We further confirm that in case, any of the information noted above is found to be incorrect, I / We will be liable for any action under the terms of the tender / contract including termination of the contract and forfeiture of the Earnest Money / Security Deposit.

I / We hereby undertake and agree to pay the Security Deposit as per the tender conditions within seven days from the date of issue of Letter of Acceptance.

---



I / We undertake to sign the contract with the Corporation within seven days from the date of issue of Letter of Acceptance.

I / We further agree that the acceptance of the tender conditions would, by itself, constitute a valid and concluded contract binding on me/us, even if separate contract is not signed.

I / We further agree that in the event of my/our failing to deposit securities mentioned above or to produce the latest income tax and GST clearance certificate or to execute the Contract within the period of seven days as referred to above, the EMD of **Rs. 2,55,000 (Rupees Two lakhs fifty five thousand only)** deposited with the tender shall be forfeited by the Tamil Nadu Textbook and Educational Services Corporation and in addition, the Managing Director, Tamil Nadu Textbook and Educational Services Corporation , shall be entitled to cancel the contract and there upon arrange for any other person or persons to supply the materials herein before mentioned and I / We agree to be liable for all damages, losses, charges and expenses arising from or by reason of such failure on our part.

I / We hereby further agree and undertake that:

- a. In case, there is any defect found in the Geometry box or in any part of the Geometry box delivered, we undertake to replace the same by a new one.
- b. If the Geometry box delivered is found to have even the slightest damage, due to any reason like in the process of transportation, the material should be replaced by a new one.

I / We hereby declare that I / We agree to do the various acts, deeds and things referred to herein, for enabling the Corporation to procure **the Geometry box conforming to specifications.**

Having fully understood the tender conditions and the above undertaking in this letter, I / we sign this \_\_\_\_\_ Day of \_\_\_\_\_ at \_\_\_\_\_.

Yours faithfully,

Authorized Signature :

Name & Title of Signatory :

Name of the Tenderer :

Address :

**COVERING LETTER FOR TECHNICAL PROPOSAL**

(on Applicant's Letterhead)

Date: \_\_\_\_\_

From,

Name:

Address:

Ph:

Fax:

E-mail:

To,

The Managing Director

Tamil Nadu Textbook and Educational Services Corporation,  
EVK Sampath Maaligai, DPI Campus, 68, College Road,  
Chennai-600 006.

Sir,

Sub : Tender for Selection of Manufacturer/Supplier for supply and delivery of Geometry box to the School Children in Tamil Nadu - Submission of Technical Proposal (Part-A) - Reg

Ref : Your Tender Notice \_\_\_\_\_ Dt. \_\_\_\_\_

With reference to your tender notice, we submit herewith our sealed Tender for Selection of Manufacturer/Supplier for supply and delivery of Geometry box to the School Children in Tamil Nadu as specified in this tender document.

We enclose the following documents:

- 1) Tender conditions duly signed in each page and enclosed in token of accepting the Tender conditions
- 2) DD/Banker's Cheque No. \_\_\_\_\_ for ₹ 2,55,000/- (Rupees Two lakhs fifty five thousand only), towards Earnest Money Deposit
- 3) DD/Banker's Cheque No. \_\_\_\_\_ for ₹ 11,800/- (Rupees Eleven Thousand Eight Hundred only), towards Bid Processing Fees (non-refundable)

- 4) Authorization letter from the tenderer for the person to sign the tender
- 5) Details of the Tenderer (as per Annexure-IV)
- 6) Address proof document for having local office in Chennai
- 7) Samples submission form (as per Annexure-V)
- 8) The copy of certificate of incorporation/registration and copy of Memorandum and Articles of Association in case of Private / Public Limited Companies
- 9) Copy of LLP registration or registered partnership deed in case of Partnership Firm
- 10) Copy of GST Registration certificate
- 11) GST Return copies for the last 3 consecutive financial years i.e. 2019-2020, 2020-2021 and 2021-2022.
- 12) Copy of Valid legal contractual agreement with Manufacturer of Crayons with validity for at least three years beyond the tender opening date (only for Supplier).
- 13) Certificate of average annual turnover duly certified by a Chartered Accountant with UDIN (as per Annexure - VI) in Original.
- 14) Annual Report / certified copies of Balance Sheet, Profit & Loss statement for the last 3 consecutive financial years i.e. 2018-19, 2019-20 and 2020-21 (or) 2019-2020, 2020-2021 and 2021-2022.
- 15) IT Return copies for the last 3 financial years.
- 16) Copies of Purchase Orders and Completion Certificates in support of the following:
  - 3 years of experience in the manufacture of Geometry box
  - Supply of 5% of tendered quantity of Geometry box per annum to any organisation in any one of the last 3 financial years 2019-2020, 2020-2021, 2021-2022 (as per Annexure VII-A)
- 17) Chartered Accountant certificate for quantity supplied in any one of the last 3 financial years (as per Annexure VII-B).
- 18) Chartered Engineer's Certificate for infrastructure and production capacity of tenderer's manufacturing unit(s) (as per Annexure-VIII) in Original
- 19) If the tenderer is a Supplier, the documents required in Sl.No. 18 shall be obtained from the manufacturer with whom the supplier has contracted and furnished in the tender.

- 20) Bank's certificate (on Bank's letterhead) for availability of credit facility or own funds and that the tenderer's account is not an NPA (as per Annexure-IX)
- 21) Net worth certified by Chartered Accountant along with UDIN (as per Annexure-X)
- 22) Declaration for not having blacklisted either by Corporation or by any other Govt. agencies (as per Annexure XI-A)
- 23) Declaration for non-adverse performance in the contract awarded by the Corporation (as per Annexure XI-B)
- 24) Declaration for not having tampered the Tender documents downloaded from the website [www.tenders.tn.gov.in](http://www.tenders.tn.gov.in) (Annexure-XII)
- 25) Declaration for Minimum Offered Quantity (as per Annexure-XIII)
- 26) Declaration for accepting Terms and Conditions of Tender (as per Annexure - XIV)
- 27) Checklist of documents enclosed as per Annexure - XVI
- 28) Notarized translated English version of the documents in a language other than English/Tamil, if any

**Yours faithfully,**

**SIGNATURE OF THE TENDERER  
(WITH SEAL)**

**Encl: As stated above**

## ANNEXURE - IV

## DETAILS OF THE TENDERER

S.No.	Particulars	Description/Details
<b>A</b>	<b>Name of Tenderer</b>	
<b>B</b>	<b>Contact Details</b>	
	Registered Office Address	
	Telephone / Mobile No.	
	Fax No.	
	Email	
	Website	
<b>C</b>	<b>Constitution of Tenderer</b>	Proprietor / Partnership firm / Company
	PAN No.	
	TAN No.	
	GST No.	
<b>D</b>	<b>Incorporation Details</b>	
	Incorporation Number (CIN/LLP No.)	
	Date of Incorporation	
	Authority	
<b>E</b>	<b>Name of Authorized Signatory</b>	
	Position	
	Telephone / Mobile No.	
	Fax No.	
	Mobile	
	Email	
<b>F</b>	<b>Address of the Manufacturing units (or contract manufacturer's units, in case of Supplier)</b>	1. 2. 3.
<b>G</b>	<b>Address of Chennai Office</b>	
<b>H</b>	<b>Details of Blacklisting by the Corporation / PSU / State or Central Government Departments / Quasi Govt. Agencies / Local Government bodies</b>	

<b>I</b>	<b>Bank Account details</b>	
	Bank name	
	Branch Name and Address	
	Account Number	
	IFSC	
	MICR	

**Add documentary proof for all the above particulars**

**SIGNATURE OF THE TENDERER  
(with seal)**

## ANNEXURE - V

## SAMPLES SUBMISSION FORM

Sl. No.	Name of the Item	Technical Specification	Quantity of samples
1	Geometry Box	Geometry box containing all mathematical drawing instruments and inner compartment	3 Nos.
2	Scale	Should be made of high quality general purpose polystyrene, virgin and clear grade.	
3	Protractor	Should be made of high quality General purpose polystyrene, virgin and clear grade.	3 Nos.
4	Set-square - Two types	Should be made of high quality general purpose polystyrene, virgin and clear grade.	3 Nos.
5	Compass- 11.5 cm	Compass should be made of rust resistant high quality MS Sheet and coated with rust resistant materials (Plated Metal) and the pencil holder with check nut should be made out of ABS Material. Hinge head should be made out of polypropylene and also the compass pointer should have plastic needle cap for protection.	3 Nos.
6	Divider- 11.5 cm	Divider should be made out of rust resistant, high quality and plated M.S. Sheet and hinge head should be made out of polypropylene and also the both pointer should have plastic needle cap for protection.	3 Nos.
7	Pencil	Half HB Pencil hexagonal shape with High quality carbon / lead point. The pencil should be non-toxic	3 Nos.
8	Sharpener	Body of the sharpener should be made of high quality polystyrene and the blade should be made of high speed carbon steel with rust resistant coating.	3 Nos.
9	Eraser	Eraser should be made of non-toxic plasticized PVC rubber material.	3 Nos.
10	Box	Thickness of the sheet used for Geometry Box should be $0.22 \pm 0.01$ mm and made out of Tin-free Mild steel (Press Metal Sheet with varnish coated). The box should have double lock.	3 Nos.
11	Inner compartment	Box should have inner compartments made out of High Impact Polystyrene	3 Nos.

Certified that the samples of Geometry boxes, mathematical drawing instruments and inside materials submitted along with the tender documents conforms to the technical specifications prescribed in Annexure I-A, I-B and I-C.

**SIGNATURE OF THE TENDERER  
(with seal)**

**ANNEXURE - VI****ANNUAL TURNOVER STATEMENT**

The Annual turnover of M/s .....  
..... for the past three years are given below.

S.No.	Year	Turnover (₹ in lakh)
1.	2018-2019	
2.	2019-2020	
3.	2020-2021	
4.	2021-2022	
	Total	
Average annual turnover for last 3 consecutive years		

Note: Average Turnover of any three consecutive financial years will be considered i.e. FY 2018-2019, 2019-20 and 2020-21 (or) FY 2019-20, 2020-21 and 2021-22.

Certified that the above statement is true and correct.

**DATE :**

**SIGNATURE OF THE TENDERER :**

**SIGNATURE OF CHARTERED ACCOUNTANT :**  
(with Seal and Address)

**UDIN :**



**ANNEXURE VII-A****DETAILS OF WORK ORDERS COMPLETED**

**List of work orders/purchase orders completed in supply of at least 5% of tendered quantity of Geometry boxes to any organisation in any one of the last 3 financial years**

*(Please provide the details for each project in a separate sheet along with purchase order from client)*

<b>Financial Year</b>	<b>Quantity of Geometry box Supplied (in Nos.)</b>
2019-2020	
2020-2021	
2021-2022	
<b>Total</b>	

*(Please provide below the details of 5% (or more) of tendered quantity of Geometry boxes supplied in a particular financial year)*

**Financial Year: \_\_\_\_\_**

<b>S.No</b>	<b>Name &amp; address of the client</b>	<b>Client Type</b>	<b>Quantity of Geometry boxes Supplied (in Nos.)</b>	<b>Work Order/ Purchase Order enclosed (Yes/No)</b>
1.				
2.				
3.				
4.				
5.				

**SIGNATURE OF THE TENDERER  
(with seal)**

**ANNEXURE VII-B**

**CHARTERED ACCOUNTANT CERTIFICATE FOR QUANTITY SUPPLIED  
IN ANY ONE OF THE LAST 3 FINANCIAL YEARS**

Certified that the firm/company M/s \_\_\_\_\_ (GST  
Registration No. \_\_\_\_\_) has supplied \_\_\_\_\_ nos. of Geometry  
boxes valued at ₹\_\_\_\_\_ in the financial year \_\_\_\_\_.

This certificate is issued based on verification of the firm/company's GST Invoices  
produced before me.

**DATE :**

**SIGNATURE OF CHARTERED ACCOUNTANT :**  
(with Seal and Address)

**UDIN :**

**ANNEXURE - VIII****CHARTERED ENGINEER CERTIFICATE**

This is to certify that I have verified the Plant and Machinery belonging to M/s\_\_\_\_\_ having its registered office at \_\_\_\_\_ and manufacturing unit at \_\_\_\_\_ village, \_\_\_\_\_ tehsil/taluk, \_\_\_\_\_ district, \_\_\_\_\_ State has been inspected by me on \_\_\_\_\_ (date) to assess the infrastructure and production capacity of the Unit. This certification is given on their request to furnish the unit's infrastructure and production capacity to **Tamil Nadu Textbook and Educational Services Corporation.**

The requisite details of the unit are provided in the Tables below.

S. No.	Licences and Approvals	Document No. and issued date	Valid till	Issued by
1	Factory Licence/Registration under Factories Act with DISH			
2	Consent to Operate from State Pollution Control Board			
3	BIS Registration / ISO			
4	EB service connection No.			
5	Provident Fund Account no.			
6	ESI Registration No.			
7	NABL Accreditation			

**Connected load in KW:**

The details of plant & machinery and QC/testing equipment, raw material store, packing section, finished goods store, despatch area and canteen (if any) are provided in the Tables below.

**TABLE 1: PRODUCTION MACHINERY INSTALLED AT THE UNIT**

S. No.	Name of machinery in the unit	Make/ Model	Year of manufacture	No. of machines	Production capacity per shift (A)	No. of Operators	Electrical load in KW
1							
2							
3							
4							
5							
6							

S. No.	Name of machinery in the unit	Make/ Model	Year of manufacture	No. of machines	Production capacity per shift (A)	No. of Operators	Electrical load in KW
7							
8							
9							
10							
<b>TOTAL</b>					_____ Geo- metry boxes	<b>Nos.</b>	<b>KW</b>

- A. Production capacity per shift = \_\_\_\_\_ Geometry boxes/shift  
 B. No. of Shifts per day = 1 / 2 / 3  
 C. Production capacity per day (A x B) = \_\_\_\_\_ Geometry boxes/day  
 D. No. of days of operation in a year = \_\_\_\_\_ days/year  
 E. Production capacity per year (C x D) =  Geometry boxes/year

**TABLE 2: QUALITY CONTROL AND TESTING EQUIPMENT**

S. No.	Name of machinery installed in unit	Make/ Model	Year of manufacture	No. of machines installed	Electrical load in KW or HP
1	Analytical balance				
2	Thermometer (accuracy 0.1 C)				
3	Hardness Tester				
4	Electronic Weighing scale of 5kg capacity (accuracy-1g)				
5					
6					
7					
8					

**TABLE 3: BUILT-UP AREA (PRODUCTION FACILITY AREA)**

S. No.	Name of Production Area	Length in M	Breadth in M	Area in M <sup>2</sup>
1	Raw Material Store			
2	Pre-production area			
3	Production area			
4	Quality Control/Testing laboratory			
5	Packing section			
6	Finished goods section			
7	Despatch section			
8				

S. No.	Name of Production Area	Length in M	Breadth in M	Area in M <sup>2</sup>
9				
10				
<b>TOTAL NON-PRODUCTION AREA</b>				<b>Sq.M.</b>

**TABLE 4: BUILT-UP AREA (ADMINISTRATION AND NON-PRODUCTION AREA)**

S. No.	Name of Non-production area	Length in M	Breadth in M	Area in M <sup>2</sup>
1	Administration block			
2	Utilities (Compressor etc.)			
3	Workshop			
4	Generator room			
5	Security Room			
6	Toilet block			
7				
8				
<b>TOTAL NON-PRODUCTION AREA</b>				<b>Sq.M.</b>

**TABLE 4: RAW MATERIALS AND MANUFACTURER/SUPPLIERS**

S. No.	Name of Raw Material	Name of Manufacturer/ Supplier	Remarks
1	Box - Tin-free Mild steel (Press Metal Sheet with varnish coated)		
2	Inner compartment - High Impact Polystyrene		
3	Scale - polystyrene, virgin and clear grade		
4	Protractor - polystyrene, virgin and clear grade		
5	Set-square (Two types) - polystyrene, virgin and clear grade		
6	Compass (11.5 cm) - MS Sheet (Plated Metal), pencil holder with check nut -ABS Material, Hinge head - polypropylene		
7	Divider (11.5 cm) - MS Sheet (Plated Metal), Pointer cap - Plastic Material, Hinge head - polypropylene		
8	Pencil - Half size, HB Pencil, hexagonal shape		
9	Sharpener, Body - Polypropylene, Blade - high speed carbon steel with rust resistant coating		
10	Eraser - non-toxic plasticized PVC rubber material		
11			
12			

**TABLE 4: STAFF STRENGTH**

S. No.	Category	Staff Nos.
1	Managerial	
2	Technical	
3	Non-technical	
4	<b>QC/Testing</b>	
5	Packers	
6	Helpers	
7		
8		
<b>TOTAL</b>		<b>Nos.</b>

I certify that the production capacity of M/s \_\_\_\_\_ unit located at \_\_\_\_\_ is \_\_\_\_\_ (quantity) Geometry boxes per year.

I confirm that the details provided are true and correct to the best of my knowledge and belief.

Place:

**Chartered Engineer's Signature:**

Date:

**Address:**

**Official Seal/Stamp:**

**Mobile No:**

**Registration No:**

- Note:** 1. If more than one manufacturing unit is available, please submit separate certificate for each facility.
2. If tenderer is a Supplier, the tenderer has to submit Chartered Engineer Certificate of the contract manufacturing unit.

**ANNEXURE - IX**

**FORMAT FOR BANK'S CERTIFICATE FOR AVAILABILITY OF CASH CREDIT FACILITIES/  
OWN FUNDS**

(on Scheduled Commercial Bank's letterhead)

This is to certify that M/s \_\_\_\_\_ having current account no. \_\_\_\_\_ with our bank, is a company/firm with good financial standing.

The company/firm has Cash Credit facility / own funds of ₹\_\_\_\_\_ crores as on date.

If the contract for the supply of Geometry box to school children in Tamil Nadu is awarded by Tamil Nadu Textbook and Educational Services Corporation to the above company/firm, we shall provide an **exclusive credit facility** up to a maximum of ₹ \_\_\_\_\_ crores to meet their working capital requirements for executing the contract.

We also certify that the account has not been declared as NPA as on date.

Place:

Signature:

Date:

**Name of Authorised signatory**

**Designation with seal**

**Bank Name**

**Address of branch**

**NET WORTH CERTIFICATE**

Certified that the net worth of M/s \_\_\_\_\_  
as on 31.03.2022 is ₹ \_\_\_\_\_.

DATE :

**SIGNATURE OF THE TENDERER :**

**SIGNATURE OF CHARTERED ACCOUNTANT :**  
(with seal, membership no. and Address)

UDIN :



**ANNEXURE XI-A**

**DECLARATION FOR NOT HAVING BLACKLISTED**

Date: \_\_\_\_\_

I/We declare that M/s\_\_\_\_\_ /the firm/ company or its partners / shareholders have not been blacklisted in the last 5 years as on the date of tender opening by the Corporation or Central / State Government departments and Quasi Government Organizations.

I/We understand that even if the blacklisting was subsequently revoked, I/we are **not eligible** to participate in the tender.

**SIGNATURE OF THE TENDERER  
(with seal)**

**ANNEXURE XI-B**

**DECLARATION FOR NON-ADVERSE PERFORMANCE**

Date: \_\_\_\_\_

1. I/We declare that there has not been any adverse performance in the contract awarded to us by the Corporation in the last 3 financial years i.e., in 2019-20, 2020-21 and 2021-22 in terms of the following.
  - a) Non-execution of Agreement
  - b) Forfeiture of Security deposit
  - c) Non-supply of ordered quantity either partially or fully.
  - d) Termination of contract
  
2. I/We have not been awarded any contract by the Corporation in the last 3 financial years i.e., in 2019-20, 2020-21 and 2021-22.

*(Strike out - 1 or 2 as applicable)*

**SIGNATURE OF THE TENDERER  
(with seal)**

**DECLARATION FOR NOT HAVING TAMPERED TENDER DOCUMENT**

Date: \_\_\_\_\_

- a) I/We \_\_\_\_\_ having our office at \_\_\_\_\_ do declare that I/We have carefully read all the conditions of tender sent to me/us by Corporation, for the tenders floated vide tender ref.no.9359/PUR-II/2022 for the Selection of Manufacturer/Supplier for supply and delivery of Geometry box to the School Children in Tamil Nadu as per the tender conditions.
- b) I/We have downloaded the tender document from the internet site [www.textbookcorp.tn.gov.in](http://www.textbookcorp.tn.gov.in) and [www.tenders.tn.gov.in](http://www.tenders.tn.gov.in) and I / We have not tampered / modified the tender document in any manner. In case, if the same is found to be tampered / modified, I/ We understand that my/our tender will be summarily rejected and full Earnest Money Deposit will be forfeited and I /We am/are liable to be banned from doing business with Corporation or prosecuted.

**SIGNATURE OF THE TENDERER  
(with seal)**

**ANNEXURE - XIII**

**DECLARATION FOR MINIMUM OFFERED QUANTITY**

Date: \_\_\_\_\_

Declared that I / We \_\_\_\_\_ offer to supply a quantity of \_\_\_\_\_ Geometry boxes to **Tamil Nadu Textbook and Educational Services Corporation** fully complying with the terms and conditions of the tender within 75 days.

I am / We are aware that as per Tender conditions, the minimum offered quantity should be 2,00,000 Geometry boxes.

**SIGNATURE OF THE TENDERER  
(with seal)**

**ANNEXURE - XIV**

**DECLARATION FOR ACCEPTING TERMS AND CONDITIONS OF TENDER**

Date: \_\_\_\_\_

- a) I/We ..... having the registered office at..... declare that I/we have carefully read and accept all the terms and conditions of Tender floated by the Tamil Nadu Textbook and Educational Services Corporation, Chennai vide Tender Ref.No. 9359/PUR-II/2022 for the purchase of 13,42,757 Geometry boxes strictly conforming to the specifications as given in the Tender Document and I / we shall abide by all the conditions set forth therein.
- b) I/we also undertake to take back the rejected defective and the test- failed Geometry box at my/our risk & cost and replace the same within the stipulated time as per instructions of Tamil Nadu Textbook and Educational Services Corporation, Chennai.

**SIGNATURE OF THE TENDERER  
(with seal)**

## ANNEXURE- XV

## CLARIFICATION ON TENDER DOCUMENT

TENDERER'S REQUEST FOR CLARIFICATION			
Name and Address of the Organization submitting request		Name and Position of Person submitting request	Contact Details of the Organization/Authorized Representative
			Tel:
			Fax:
			Email:
S. No.	Reference(s) (Section, Page)	Content of Tender requiring Clarification	Points of clarification required
1			
2			
3			

**SIGNATURE OF THE TENDERER  
(with seal)**

## ANNEXURE - XVI

## CHECKLIST OF DOCUMENTS - PART-A (TECHNICAL BID)

S. No.	Checklist	Enclosed (Yes/No)	Reference to the Tender (Page No.)
1.	A letter of the tenderer in the prescribed format addressed to Tamil Nadu Textbook and Educational Services Corporation, EVK Sampath Maaligai, DPI Campus, 68, College Road, Chennai - 600 006 (as per Annexure - II)		
2.	A covering letter on official letterhead of tenderer addressed to Tamil Nadu Textbook and Educational Services Corporation, EVK Sampath Maaligai, DPI Campus, 68, College Road, Chennai - 600 006 (as per Annexure-III)		
3.	Tender conditions duly signed on each page and enclosed in token of accepting the Tender conditions		
4.	Demand Draft / Banker's cheque No. _____ dated _____ for ₹ 2,55,000/- towards Earnest Money Deposit		
5.	If EMD exemption is claimed, supporting documents for claiming exemption of EMD have to be enclosed (i.e. NSIC / MSME / DIC certificate).		
6.	Demand Draft / Banker's cheque No. _____ dated _____ for ₹ 10,000 + 18% GST aggregating to ₹ 11,800/- towards Bid Processing Fee (NON-REFUNDABLE).		
7.	Details of the Tenderer (as per Annexure-IV)		
8.	Authorization letter from the tenderer for the person to sign the tender		
9.	Whether a Video CD covering the entire manufacturing process of the manufacturing unit from the raw material stage to the finished product is furnished?		
10.	Samples submission form for Geometry box and raw materials (as per Annexure-V)		
11.	Whether three samples of Geometry box as per specifications are furnished?		
12.	Whether samples of raw materials for manufacturing the Geometry box are enclosed in a sealed cover. (Quantity as		

S. No.	Checklist	Enclosed (Yes/No)	Reference to the Tender (Page No.)
	specified in Annexure I-C)		
13.	Copy of Memorandum and Articles of Association		
14.	Copy of Registration for LLP/registered partnership deed in case of Partnership Firm		
15.	Copy of GST Registration certificate		
16.	Copy of Valid legal contractual agreement with Manufacturer of Crayons with validity for at least three years beyond the tender opening date (only for Supplier).		
17.	Average annual turnover for last 3 financial years duly certified by Chartered Accountant along with UDIN (as per Annexure - VI) in Original		
18.	Annual Report / certified copies of Balance Sheet, Profit & Loss statement for the last 3 consecutive financial years i.e. 2018-19, 2019-20 and 2020-21 (or) 2019-20, 2020-21 and 2021-22.		
19.	IT Return copies for the last 3 financial years		
20.	Details of works completed i.e. at least 5% of tendered quantity of Geometry box to any organisation in any one of the last 3 financial years 2019-2020, 2020-2021, 2021-2022 along with copies of tax invoices and completion certificates (as per Annexure VII-A).		
21.	Chartered Accountant certificate for quantity supplied in any one of the last 3 financial years (as per Annexure VII-B).		
22.	GST Return copies for the last 3 consecutive financial years i.e. 2019-2020, 2020-2021 and 2021-2022		
23.	Chartered Engineer's Certificate for infrastructure and production capacity of tenderer in original (as per Annexure-VIII)		
24.	In case of Supplier, Chartered Engineer's Certificate shall be obtained from the crayon manufacturer with whom the supplier has contracted (as per Annexure-VIII)		
25.	Letter from Bank (on Bank's letterhead) in support of credit facility or own funds & that tenderer's account is not an NPA (as per Annexure-IX).		



S. No.	Checklist	Enclosed (Yes/No)	Reference to the Tender (Page No.)
26.	Net worth certified by Chartered Accountant along with UDIN (as per Annexure-X) in Original		
27.	Declaration for not having blacklisted either by Corporation or by any other Government agencies (as per Annexure XI-A).		
28.	Declaration for non-adverse performance in the contract awarded by the Corporation (as per Annexure XI-B)		
29.	Declaration for not having tampered the Tender documents downloaded from the website www.tenders.tn.gov.in (as per Annexure-XII).		
30.	Declaration of Minimum Offered Quantity (as per Annexure-XIII)		
31.	Declaration for accepting Terms and Conditions of Tender (as per Annexure - XIV)		
32.	Proof for having a local office in Chennai		
33.	Notarized translated English version of the documents in a language other than English/Tamil, if any.		

**Note: Tenders submitted in unsealed cover would be summarily rejected.**

**SIGNATURE OF THE TENDERER  
(with seal)**

**CHECKLIST OF DOCUMENTS - PART-B (PRICE BID)**

<b>S. No.</b>	<b>Checklist</b>	<b>Enclosed (Yes/No)</b>	<b>Reference to the Tender (Page No.)</b>
1.	A covering letter on official letterhead of the tenderer in the prescribed format addressed to Tamil Nadu Textbook and Educational Services Corporation, EVK Sampath Maaligai, DPI Campus, 68, College Road, Chennai - 600 006 (as per Annexure - XVII)		
2.	Financial Bid - Part-B (as per Annexure - XVIII)		

**SIGNATURE OF THE TENDERER  
(with seal)**

**ANNEXURE - XVII**

**PART - B**

**COVERING LETTER FOR FINANCIAL PROPOSAL (PRICE BID)**

(on Applicant's Letterhead)

Date: \_\_\_\_\_

From,  
Name:  
Address:  
Phone:  
Fax:  
E-mail:

To,  
The Managing Director  
Tamil Nadu Textbook and Educational Services Corporation, EVK  
SAMPATH MAALIGAI, DPI Campus,  
68, College Road, Chennai-600 006

Sir,

Sub : Tender for Selection of Manufacturer / Supplier for supply and delivery of Geometry boxes to the School Children in Tamil Nadu - Submission of Financial Proposal (Part-B) - Reg

Ref : Your Tender Notice \_\_\_\_\_ Dt. \_\_\_\_\_

With reference to your tender notice, we submit herewith our sealed Financial Proposal (Price Bid) as Annexure - XVIII for Selection of Manufacturer/Supplier for supply and delivery of Geometry boxes to the School Children in Tamil Nadu as specified in this tender document.

I/We agree that enclosed Financial Proposal (Price Bid) shall remain valid for a period of 120 (One hundred Twenty) days from the date of opening of Tender or for such further period that will be mutually agreed upon by the Tenderer and Corporation.

**Yours faithfully,**

**Signature of the Tenderer  
(Seal)**

**Encl: Financial Proposal (Part-B)**

## FINANCIAL PROPOSAL (Part-B)

Tender for Selection of Manufacturer/Supplier for supply and delivery of  
Geometry boxes to the School Children in Tamil Nadu

Sl. No.	Details	Rate per Geometry box	
		Amount in Figures	Amount in Words
1	Basic Cost	₹	
2	GST @ _____ %	₹	
	<b>TOTAL COST</b>	₹	
<b>Total amount (₹ in Words)</b>			

Yours faithfully,

Signature of the Tenderer  
(Seal)

**FORMAT FOR BANK GUARANTEE FOR SECURITY DEPOSIT**

To: \_\_\_\_\_ [name of Employer]  
\_\_\_\_\_ [address of Employer]

WHEREAS \_\_\_\_\_ [name and address of Successful Tenderer] (hereinafter called "the Successful Tenderer") has undertaken, in pursuance of Tender No. \_\_\_\_\_ dated \_\_\_\_\_ to execute \_\_\_\_\_ [name of Contract and brief description of Works] (hereinafter called "the Contract");

AND WHEREAS it has been stipulated by you in the said Contract that the Successful Tenderer shall furnish you with a Bank Guarantee by a scheduled commercial bank for the sum specified therein as security for compliance with his obligations in accordance with the Contract;

AND WHEREAS we have agreed to give the Successful Tenderer such a Bank Guarantee;

NOW THEREFORE we hereby affirm that we are the Guarantor and responsible to you, on behalf of the Successful Tenderer, up to a total of \_\_\_\_\_ [amount of guarantee] <sup>1</sup> \_\_\_\_\_ [in words], such sum being payable in the types and proportions of currencies in which the Contract Price is payable, and we undertake to pay you, upon your first written demand and without cavil or argument, any sum or sums within the limits of \_\_\_\_\_ [amount of guarantee] <sup>1</sup> as aforesaid without your needing to prove or to show grounds or reasons for your demand for the sum specified therein.

We hereby waive the necessity of your demanding the said debt from the Successful Tenderer before presenting us with the demand.

We further agree that no change or addition to or other modification of the terms of the Contract or of the Works to be performed there under or of any of the Contract documents which may be made between you and the Successful Tenderer shall in any way release us from any liability under this guarantee, and we hereby waive notice of any such change, addition or modification.

This guarantee shall be valid until **18** Calendar months from the date of issue of Bank Guarantee.

Signature and seal of the guarantor \_\_\_\_\_

Name of Bank \_\_\_\_\_

Address \_\_\_\_\_

Date \_\_\_\_\_

- <sup>1</sup> An amount shall be inserted by the Guarantor, representing the percentage of the Contract Price specified in the Contract including additional security for unbalanced Bids, if any and denominated in Indian Rupees.

**MODEL AGREEMENT FORM**

**AGREEMENT**

This Agreement made this \_\_\_<sup>th</sup> day of \_\_\_\_\_ 2022 BETWEEN TAMILNADU TEXTBOOK AND EDUCATIONAL SERVICES CORPORATION, EVK Sampath Maaligai, DPI Campus, 68, College Road, Chennai - 600 006, herein after referred to as “Corporation” on ONE PART and M/s. \_\_\_\_\_

\_\_\_\_\_ (Name & Address of Manufacturer / Supplier) represented by its \_\_\_\_\_, Shri. \_\_\_\_\_, hereinafter called the “SUPPLIER” on the OTHER PART.

1. Whereas Corporation desired to purchase Geometry box, by calling tenders which were opened on \_\_\_\_\_.
2. And whereas Supplier, M/s. \_\_\_\_\_), has made an offer to supply and deliver the Geometry boxes on \_\_\_\_\_.
3. And whereas the Supplier has quoted all inclusive rate of ₹ \_\_\_\_\_/- (Rupees \_\_\_\_\_ only) for the supply and delivery of Geometry boxes.
4. And whereas the Supplier after due negotiation agreed to undertake the contract of supply and delivery of Geometry boxes at ₹ \_\_\_\_\_/- (Rupees \_\_\_\_\_ only) inclusive of all duties & taxes.
5. Whereas Corporation has accepted the negotiated rate of the Supplier vide letter No. \_\_\_\_\_ dated \_\_\_\_\_.
6. And whereas both Corporation and the Supplier have agreed to execute an agreement setting out the terms and conditions here under mentioned as agreed to by both the parties to this agreement.

**7. NOW THIS DEED OF AGREEMENT WITNESSES:**

(i) EMD and Security Deposit

- a) The Supplier has remitted an amount of ₹ 2,55,000/- (Rupees Two lakhs fifty five thousand only) towards Earnest Money Deposit (EMD) in the form of in the form of Demand Draft / Banker’s cheque on any Scheduled Commercial Bank in favour of the “Tamil Nadu Textbook and Educational Services Corporation, Chennai”.

- b) The “Supplier” has remitted an amount of ₹ \_\_\_\_\_/-(Rupees \_\_\_\_\_only) towards Security Deposit (SD) being 5% of the allotted quantity after adjusting the Earnest Money Deposit of ₹ 2,55,000/-, in the form of Demand Draft / Banker’s cheque on any Scheduled Commercial Bank in favour of the “Tamil Nadu Textbook and Educational Services Corporation or by an Irrevocable Bank Guarantee with a validity period of 18 months from any Indian Scheduled Commercial Bank, within 7 (Seven) working days from the date of receipt of letter of acceptance. The EMD shall be adjusted with the Security Deposit.
- c) Any other amount pending with Corporation will not be adjusted under any circumstances, against the Security Deposit if so requested.
- d) Security Deposit will be returned only after the completion of the Contract in full without any deficiency or default and to the entire satisfaction of the Corporation and on completion of the warranty period of 6 months post supply. The Security Deposit so held by the Corporation, shall not earn any interest till it is returned to the successful tenderer(s).
- e) In case of non-fulfilment of the contract and/or failure to supply the ordered quantity of Geometry boxes in full or part within the delivery period as per the terms and conditions stipulated in the tender, the Security Deposit will be forfeited.

(ii) The detailed price schedule is given as under:

S.No.	Item Description	Total Price inclusive of GST (in ₹ )
1		

## 8. ISSUE OF PURCHASE ORDER

After furnishing the security deposit and execution of the agreement, Purchase Order, Purchase Order will be issued indicating the size, quantity, points of delivery, schedule of supply, etc. The successful tenderer should supply ordered items as per the schedule given in Clause No. 12. Brief particulars of the Geometry box, which shall be supplied / delivered by the Supplier are:

Item Description	Quantity allotted	Accepted Rate inclusive of GST (in ₹)	Total Value inclusive of GST (in ₹)
<b>Total</b>		-	



**9. POINTS OF DELIVERY**

The Geometry boxes are to be delivered at 534 designated delivery points indicated in the Purchase Order. The Corporation reserves its right to allot any delivery point in Tamil Nadu for operational convenience. The successful tenderer will not have any right to ask for change of delivery points.

**10. EXTENSION OF VALIDITY PERIOD OF CONTRACT**

The Tender Inviting Authority may extend the validity period of contract for further one year on the same terms & conditions.

**11. SCHEDULE OF SUPPLY**

- (a) The allotted quantity of Geometry boxes is to be delivered at the designated delivery points as given below:

**T = Date of issue of Purchase Order**

Sl.No.	Milestone	Due date of Delivery (days)
1	25% of the ordered quantity	T + 30
2	50% of the ordered quantity	T + 45
3	75% of the ordered quantity	T + 60
4	100% of the ordered quantity	T + 75

- (b) The entire ordered quantity of Geometry boxes complying with the technical specifications mentioned in the Annexure I-A, I-B, I-C and I-D of the Tender Document shall be completed within 75 days from the date of issue of the Purchase Order.
- (c) The successful tenderer shall stick/print LOGO / TEXT etc. as per the instructions of Corporation on the items supplied.
- (d) The Geometry box shall be delivered to the designated locations of Block Educational Officers / District Educational Officers in the State of Tamil Nadu as per the Purchase Order in good condition. The Transit / Freight charges, Insurance, all the Taxes, Loading and Unloading charges and all other incidental charges for the supply and delivery of the ordered Geometry boxes in good condition to the designated locations shall be borne by the successful tenderer at his own risk and cost.
- (e) After delivery of the Geometry boxes at the designated delivery points, the successful tenderer shall obtain acknowledgement for proof of delivery of Geometry boxes in good condition from respective DEO/BEO for submission to the Corporation.

- (f) If there is a delay beyond 30 days with respect to the due date of delivery stated in Clause 11 (a), the unsupplied quantity will be cancelled without any prior notice and allotted to the other suppliers. Notwithstanding the above, the Corporation has the right to permit the Supplier beyond 30 days with penalty, in case of exigencies.
- (g) The Corporation reserves the right to purchase the unsupplied quantity arising due to cancellation/termination, from the open market. The consequential loss sustained by the Corporation to this effect shall be deducted from the bill of the Supplier and / or from the Security Deposit without prior intimation.
- (h) The Corporation shall have the right to terminate the contract of the successful tenderer who fails to deliver the Geometry box in full as per the purchase order and the delivery schedule.
- (i) The Supplier shall be disqualified in participating in future tender for the abnormal delay in supply, (i.e.) more than 90 days from the due date of supply for the forthcoming 1 year.

## 12. SUBMISSION OF DELIVERY PLAN

- (a) The successful tenderer has to submit a supply schedule for delivery of ordered quantity as per **Annexure - XXII** within 5 days from the date of purchase order to the Corporation.
- (b) The successful tenderer is required to submit weekly production plan by email to the Corporation on every Friday before 3 PM, starting from the date of commencement of regular production covering the following:

(i)	Raw material stock available in tenderer's warehouse	Inventory breakup of each component & mathematical instrument equivalent to _____ no. of Geometry boxes.
(ii)	Work in Progress	_____ no. of Geometry boxes
(iii)	Finished products stock in the tenderer's warehouse	_____ no. of Geometry boxes
(iv)	Quantity despatched	_____ no. of Geometry boxes
(v)	Cumulative quantity despatched	_____ no. of Geometry boxes

- (c) The Corporation reserves its right to physically verify the correctness of the particulars furnished by the tenderer. Any discrepancy will lead to reduction of allotted quantity.

### 13. PRE-DESPATCH INSPECTION

- (a) Regular inspection and in-house tests shall be conducted on the compliance of specifications and quality parameters of the Geometry boxes while being manufactured at the premises of the Manufacturer's unit (or contract manufacturer's unit, in case of Supplier) by in-house QC personnel.
- (b) 10 samples from a lot of 10,000 Geometry boxes shall be taken at random by the QC personnel of the manufacturing unit (or contract manufacturer's unit, in case of Supplier) and out of which, one sample will be subjected to the in-house Lab Test at the premises of the Manufacturer's unit (or contract manufacturer's unit, in case of Supplier). If the sample fails in the tests, the entire lot of 10,000 Geometry boxes has to be separated and moved out of the premises.
- (c) The Supplier is required to maintain proper record of all the in-house tests and shall submit weekly test record on every Monday before 3 PM by email to the Corporation, starting from the date of commencement of regular production.
- (d) The Mathematical Drawing Instruments as specified in the Annexure I-A, I-B, I-C and I-D shall be kept inside a Geometry Box. The QC cleared Geometry boxes are to be packed in non-hazardous pouches of appropriate size and 100 such Geometry boxes shall be packed in a corrugated box with sufficient buffer to avoid any damage during transit.

### 14. POST-DELIVERY TESTING

- (a) It shall be the responsibility of the Supplier to ensure that the Geometry boxes are delivered in good condition complying with the specifications and quality parameters as mentioned in Annexure I-A, I-B, I-C and I-D.
- (b) Post-delivery testing of the Geometry boxes will be carried out educational district wise.
- (c) One sample for every 5,000 Geometry boxes and/or part thereof delivered at BEO/DEO offices of an education district, shall be drawn randomly by the officials of the educational department and sent to the Corporation in a sealed cover/box. The Corporation will send the sample to a Government approved/NABL accredited testing laboratory for testing.
- (d) If the sample fails in the tests, the entire quantity of 5,000 Geometry boxes and/or part thereof attributable to the failed sample will be rejected. The Supplier has to make fresh supply equivalent to the rejected quantity without any additional cost. Further, a penalty of 10% of the value of rejected quantity will also be levied by the Corporation. The rejected Geometry box

will be withheld and returned to the Supplier only after completing the entire ordered quantity.

- (e) If the fresh supply for the rejected quantity of 5,000 Geometry boxes and/or part thereof is delivered beyond 75 days, the rejected quantity will not be returned to the Supplier.
- (f) If more than 10 samples / 10% of the ordered quantity (whichever is higher) fail in the tests, in addition to imposing penalty, the Supplier will be blacklisted for the forthcoming 1 (one) year.
- (g) The charges including the testing charges, freight charges, travelling expenses and other incidental expenses shall be borne by the Supplier.

#### **15. PACKING AND LABELLING**

- (a) The Mathematical Drawing Instruments as specified in the Annexure I-A, I-B, I-C and I-D shall be kept inside a Geometry Box. Each Geometry box shall be packed in a non-hazardous pouch of appropriate size.
- (b) 100 Geometry boxes packed in non-hazardous pouches shall be placed in a corrugated box with sufficient buffer to avoid any damage during transit. The corrugated box shall be made from Kraft paper of 150 GSM, 5 Ply and Burst Factor of 14.
- (c) Each corrugated box shall be labelled and the label shall contain the following: NOT FOR SALE, SCHEME OF SUPPLY OF COST-FREE GEOMETRY BOX TO SCHOOL CHILDREN by the Department of School Education, Government of Tamil Nadu, Supplier code no., District code, Block code, Serial number, Box number, Date, Month and Year of manufacturing of the Geometry box and quantity of Geometry boxes. The Corporation will provide the format of the label at the time of Purchase Order.

#### **16. INSURANCE**

The delivery of the quality tested Geometry boxes in fully packed and labelled condition as per the statutory norms and the specifications given in the Tender Document to the designated delivery points in time shall be the responsibility of the Supplier. The transit loss / theft / pilferage / damage of the Geometry box under any circumstance shall be the liability of the Supplier. Insurance and transit insurance of the Geometry box shall be the liability of the Supplier.

#### **17. WARRANTY & AFTER SALES SERVICE**

The warranty of the Geometry box supplied by the Supplier shall be for a period of six months from the date of distribution of the same to the school children in each block in each District in Tamil Nadu. The Supplier shall replace

the defective Geometry boxes with new ones at his cost at the designated points during the period of Warranty.

Defective Geometry boxes, if any, indicated in the feedback form obtained from beneficiary students through the respective DEOs / BEOs shall be replaced with new Geometry boxes at the designated delivery points at his cost.

## **18. PAYMENT TERMS**

- (a) No advance payment is permissible.
- (b) Payment will be processed after satisfactory delivery of entire quantity of Geometry boxes to the designated delivery points at the BEO/DEO in a district.
- (c) The delivery reports along with delivery challans signed by the concerned Block Educational Officers / District Educational Officers with acknowledgement duly affixed with proper seal are to be submitted to the Corporation.
- (d) Based on the acknowledgements issued by the Block Educational Officers / District Educational Officers, the bills will be admitted and processed. 80% of the bill value will be paid ordinarily in 30 days after post-test clearance report.
- (e) Out of the remaining 20% of the billed amount, 15% shall be paid after satisfactory feedback from schools on the quality of the Geometry boxes, duly deducting the penalty (if any), testing charges, and other incidental charges.
- (f) The remaining 5% of the billed amount shall be paid after the completion of 6 months' warranty period.
- (g) All payments under this Contract shall be made to the Bank Accounts of the Successful tenderer.
- (h) The Corporation reserves the right to recover any dues from the Supplier, which is found on later date, during audit/excess payment, after final settlement is made to them. The tenderer is liable to pay such dues to the Corporation immediately on demand, without raising any dispute/protest.
- (i) The bill raised by the Supplier shall have all Registration Numbers (GST/TAN/CIN) printed on the Bill. The validity of the Tax Registration during the currency period of the Contract shall be the sole responsibility of the Successful Tenderer.

## **19. PENALTY**

- (a) If the successful tenderer fails to deliver 50% of the ordered quantity within the due date specified in Schedule of Supply [Clause 11 (a)], the Corporation shall have the right to impose penalty of 1% of the value of the delayed supply with applicable GST (which includes the date of replacement of defective Geometry box) for every week of delay or part thereof after the due date of delivery for a period of Two weeks and thereafter at the rate of 3% of the value of the

delayed supply with applicable GST for each Week of delay or part till completion. Maximum penalty shall be limited to 10% of the total contract value.

- (b) The Corporation reserves the right to purchase the unsupplied quantity arising due to cancellation/termination, from the open market. The consequential loss sustained by the Corporation to this effect shall be deducted from the bill of the Supplier and / or from the Security Deposit without prior intimation.
- (c) In respect of replacement of Geometry boxes, the date of replacement will be taken as actual date of supply. In such cases, the ordered quantity of Geometry box for that location where the replacement was made will be taken for calculation of delay penalty. Total number of days for delay penalty will be reckoned as under:
  - (i) No. of days for delay penalty as per Clause 19 (a)
  - (ii) No. of days from the date of intimation of rejection to the date of delivery of fresh supply for the rejected quantity
  - (iii) Total number of days for delay penalty = (i) + (ii)
- (d) If the Geometry boxes supplied are found to be inferior in quality with respect to pre-approved specifications, there shall be replacement of the entire lot and/or a fine up to 10% of the defective lot.

## **20. LIQUIDATED DAMAGES**

- (a) The successful tenderer shall not manufacture, market, sell or supply the Geometry boxes manufactured, packed and labelled as per the Technical specifications in the Tender Document exclusively for distribution among the School Children studying in Government and Aided schools in Tamil Nadu. The Corporation shall impose penalty of not less than ₹ 5,00,000/- (Rupees Five Lakh Only) every time for violation of the aforesaid condition. The penalty shall be in addition to the Civil and Criminal action taken by the Corporation against such successful tenderer(s) in default.
- (b) The Corporation shall have the right to blacklist such successful tenderer(s) from participating in the subsequent Tenders of the Corporation for a minimum period of five years.

## **21. CORRUPT AND FRAUDULENT PRACTICES**

- (a) The Tenderers shall observe the highest standard of ethics during tender evaluation and supply of Geometry boxes. In order to eliminate irregularities, interference and corrupt practices in tender process by providing transparency in such matters, the Corporation defines the following terms:

- (i) 'Corrupt practice' means offering, giving, receiving or soliciting of anything of value to influence the action of a public official in the evaluation process or in contract execution.
  - (ii) 'Fraudulent practices' mean a misrepresentation of facts in order to influence the evaluation process or execution of a contract / supply to the detriment of the Corporation and includes collusive practice among tenderers (prior to or after Tender submission) designed to establish bid prices at artificial, non-competitive levels and to deprive the Corporation of the benefits of free and open competition.
- (b) The Corporation will reject a tender if it decides that the Tenderer recommended for the award has engaged in corrupt or fraudulent practices in competing for the tender.
- (c) The Corporation will declare a tenderer ineligible either indefinitely or for a stated period of time to be awarded a contract, if it any time determines that the tenderer has engaged in corrupt and fraudulent practices in competing for the tender or in executing the contract.

## **22. TERMINATION OF CONTRACT**

The Corporation reserves the right to terminate the contract at any time during the validity period on account of non-fulfilment of contract or any of the reasons.

### **(a) Termination for Default:**

- (i) If the delay continues even after 50% of the original supply period, the contract is liable to be terminated at the discretion of the Corporation.
- (ii) If the Successful Tenderer is found to have involved in fraudulent, corrupt and unfair practices in competing for or in executing the Contract;
- (iii) If the Corporation terminates the Contract in whole or in part, the Corporation may procure, upon such terms and in such manner as it deems appropriate, the Geometry box similar to those supplied and delivered and in that case, the Successful Tenderer whose contract is terminated in whole or in part shall be liable to the Corporation for any additional costs involved in procuring and supplying the Geometry box to the designated destinations. However, the Successful Tenderer shall continue the performance of the Contract to the extent not terminated. The Corporation reserves the right to take further action against the Successful Tenderer whose Contract has been terminated in whole or in part.

**(b) Termination for Insolvency:**

- (i) The Corporation may at any time terminate the Contract by giving 15 days' written notice to the Successful Tenderer without compensation to the Successful Tenderer and without incurring any liability if the Successful Tenderer becomes bankrupt or otherwise insolvent. Such termination shall not prejudice or affect any right of action or remedy that has accrued or will accrue thereafter to the Corporation.

**(c) Termination for Convenience:**

- (i) The Corporation may terminate the Contract in whole or in part at any time during the validity period of the Contract for its convenience by giving 15 days' written notice and without compensation to the Successful Tenderer. The notice of termination shall specify that termination is for the Corporation's convenience, the extent to which the Contract is terminated, and the date upon which such termination becomes effective. The termination of the contract is without prejudice to the penal consequences and damages for which the Successful Tenderer shall be liable for violation of the Contractual obligations.

**23. BLACKLISTING**

- (a) If the tenderer has submitted forged documents in this tender or if any information provided by the tenderer is found to be false/fictitious in any tender of the Government, the tenderer will be blacklisted for a period of 5 years.
- (b) If the successful tenderer fails to execute the Agreement or fails to remit the security deposit within the specified time limit, the Corporation will blacklist the tenderer for a maximum period of 3 years in addition to forfeiture of EMD.
- (c) In the event of non-performance of the contractual provisions or failure to effect the supply within the stipulated time or during the extended period, and if it is found that the contractor has not fulfilled the contractual obligation with the Corporation in any manner during the currency of the contract or also found on later date, the Corporation reserves the right to disqualify such successful tenderer to participate in future tenders or blacklist the tenderer up to a maximum period of 5 years.
- (d) Termination / full or partial cancellation of the supply of Geometry boxes to the Corporation will entail blacklisting of the Supplier for a maximum period of 3 years.
- (e) If more than 10 sample boxes / 10% of the ordered quantity (whichever is higher) fail in the tests, in addition to imposing penalty, the Supplier will be blacklisted for the forthcoming 1 (one) year.



- (f) If the successful tenderer is found to have involved in fraudulent, corrupt and unfair practices in competing for or in executing the contract the Corporation will blacklist the tenderer for a period of 5 years.
- (g) The Corporation shall have the right to blacklist the Manufacturers/Suppliers who are levied liquidated damages as per Clause 20, for a period of 5 years.
- (h) The Corporation shall have the right to blacklist the successful tenderer for breach of any Terms and Conditions of the Tender / Agreement at any point of time.

#### **24. FORCE MAJEURE**

- (a) Force Majeure means an event beyond the control of the successful tenderer and not involving the successful tenderer's fault of negligence and not foreseeable. Such event may include but are not limited to the acts of Nature such as fire, floods, epidemics, etc. and other events such as wars, revolutions, quarantine restrictions, etc.
- (b) If a Force Majeure situation arises, the successful tenderer shall promptly notify the Corporation of such conditions and the causes thereof through e-mail within 24 hours of such event. The e-mail communication shall be followed by a report with documentary evidence to be sent to the Corporation within 3 days from the date of occurrence of such event. Unless otherwise directed by the Corporation in writing, the successful tenderer shall continue to perform his obligations under the Contract to a reasonably practical extent and shall seek all reasonable alternative means for effective performance of the Contract in time.
- (c) In the event of Force Majeure, the delivery period will be extended for a period equivalent to the period during which Force Majeure event was in existence. For this period the successful tenderer shall not be liable to pay penalty. Further if the performance in whole or part, of any obligation under this Contract is prevented or delayed by reason of Force Majeure for a period exceeding 21 days, the Corporation may at its option and discretion terminate the Contract.

#### **25. GENERAL CONDITIONS**

- (a) Conditional tender in any form will not be accepted.
- (b) Corporation reserves the right to relax or waive or amend any of the tender conditions.
- (c) The right of final acceptance of the tender is entirely vested with the Corporation and Corporation reserves the right to accept or reject any or all the tenderers in part or in totality or to negotiate with any or all the tenderers

or to withdraw/ cancel/ modify this tender without assigning any reason whatsoever.

- (d) The successful tenderer shall not offload either full or part of the work to other tenderer.
- (e) Any notice regarding any problems, to the tenderer shall deemed to be sufficiently served, if given in writing by email and / or communication sent to his usual or last known place of business.
- (f) If any discrepancy was found in the tenderer's documents provided in support of qualification criteria at a later date, the Corporation has the right to cancel the order and forfeit the EMD and Security Deposit of the tenderer.

## **26. DISPUTE RESOLUTION BOARD**

A Dispute Resolution Board (DRB) shall be formed in order to resolve the disputes that may arise during the currency of the contract. The members of the DRB shall be nominated by the Corporation and the successful tenderer. If any party is not satisfied with the decision of the DRB, the issue shall be referred for Arbitration.

## **27. ARBITRATION**

- (a) The issues not resolved by DRB shall be referred for Arbitration and same shall be dealt in accordance with the Indian Arbitration and Conciliation Act, 1996 and Rules of Indian Council of Arbitration. The Arbitrator shall be selected by the successful tenderer from the panel of Arbitrators approved by the Corporation within 15 days from the date of receipt of the letter from the Corporation along with the panel. If there is no reply from the tenderer within 15 days, the Corporation shall choose any of the Arbitrators from the panel of Arbitrators referred to above. The remuneration for the Arbitrator and other expenses shall be shared equally by the Corporation and the tenderer.
- (b) The venue of the Arbitration shall be at the Head office of the Corporation in Chennai. The decision of the Arbitrator shall be final and binding on both the parties to the Arbitration. The language of the arbitration proceedings shall be in English.
- (c) The Arbitrator may with the mutual consent of the parties, extend the time for making the award. The award to be passed by the Arbitrator is enforceable in the Court at Chennai city only.

## **28. JURISDICTION OF THE COURT**

- (a) The courts in the city of Chennai exclusively shall have the jurisdiction to try any matter or dispute or reference between the Corporation and the Successful Tenderers arising out of the Contract.

(b) The Successful Tenderer is required to submit an undertaking towards jurisdiction of legal proceedings in the format enclosed in ANNEXURE - XXIII of the tender.

We agree to the above terms and conditions.

In witness whereof, Thiru. \_\_\_\_\_ on one part and Thiru. \_\_\_\_\_, \_\_\_\_\_ (Designation), M/s. \_\_\_\_\_ on the other part signed this agreement on the day, month and year first above.

Agreed by both the parties.

**SUPPLIER**

**CORPORATION**

**WITNESSES:**

**WITNESSES:**

1.

1.

2.

2.

## ANNEXURE - XXI

## LIST OF DISTRICT AND BLOCK EDUCATIONAL OFFICES IN TAMIL NADU

## List of Block Educational Offices (BEO) in Tamil Nadu

Sl. No.	Dist_id	District_name	Edu_dist_id	Edn_dist_name	Blk_id	Block_name
1	31	ARIYALUR	2	Ariyalur	430	Ariyalur
2	31	ARIYALUR	68	Sendurai	432	Andimadam
3	31	ARIYALUR	61	Udaiyarpalayam	433	Jayankondam
4	31	ARIYALUR	61	Udaiyarpalayam	434	T.Palur
5	31	ARIYALUR	2	Ariyalur	435	Thiurmanur
6	31	ARIYALUR	68	Sendurai	436	Sendurai
7	33	CHENGALPATTU	4	Chengalpattu	5	Thiruporur
8	33	CHENGALPATTU	4	Chengalpattu	6	Kattankolathur
9	33	CHENGALPATTU	4	Chengalpattu	7	Thirukalukundram
10	33	CHENGALPATTU	81	Madurantagam	8	Acharapakkam
11	33	CHENGALPATTU	81	Madurantagam	9	Lathur
12	33	CHENGALPATTU	81	Madurantagam	10	Chithamur
13	33	CHENGALPATTU	81	Madurantagam	11	Madurantagam
14	33	CHENGALPATTU	83	St.Thomas Mount	13	St.Thomas Mount(Urban)
15	33	CHENGALPATTU	83	St.Thomas Mount	14	St.Thomas Mount(Rural)
16	29	CHENNAI	8	Chennai South	410	T.Nagar
17	29	CHENNAI	5	Chennai Central	411	Adyar
18	29	CHENNAI	8	Chennai South	412	Egmore
19	29	CHENNAI	69	Chennai West	413	George town
20	29	CHENNAI	5	Chennai Central	414	Mylapore
21	29	CHENNAI	7	Chennai North	415	Perambur
22	29	CHENNAI	7	Chennai North	416	Periamedu
23	29	CHENNAI	69	Chennai West	417	Purasaiwalkkam
24	29	CHENNAI	6	Chennai East	418	Royapuram
25	29	CHENNAI	6	Chennai East	419	Triplicane
26	29	CHENNAI		Chennai		Chennai Corporation
27	11	COIMBATORE	71	SS Kulam	182	Sulthanpet
28	11	COIMBATORE	41	Pollachi	183	Anaimalai
29	11	COIMBATORE	71	SS Kulam	184	Annur
30	11	COIMBATORE	11	Coimbatore	185	Coimbatore city
31	11	COIMBATORE	11	Coimbatore	186	Karamadai
32	11	COIMBATORE	70	Perur	187	Kinathukkadavu
33	11	COIMBATORE	70	Perur	188	Madukkarai
34	11	COIMBATORE	11	Coimbatore	189	Periyanaickan Palayam
35	11	COIMBATORE	70	Perur	190	Perur
36	11	COIMBATORE	41	Pollachi	191	Pollachi north

Sl. No.	Dist_id	District_name	Edu_dist_id	Edn_dist_name	Blk_id	Block_name
37	11	COIMBATORE	41	Pollachi	192	Pollachi south
38	11	COIMBATORE	71	SS Kulam	193	Sarkar Samakkulam
39	11	COIMBATORE	71	SS Kulam	194	Sulur
40	11	COIMBATORE	70	Perur	195	Thondamuthur
41	11	COIMBATORE	41	Pollachi	196	Valparai
42	3	CUDDALORE	13	Cuddalore	29	Annagrammam
43	3	CUDDALORE	73	Vadalur	30	Bhuvanagiri
44	3	CUDDALORE	13	Cuddalore	31	Cuddalore
45	3	CUDDALORE	66	Virudhachalam	32	Kammapuram
46	3	CUDDALORE	72	Chidambaram	33	Kattumannarkoil
47	3	CUDDALORE	73	Vadalur	34	Keerapalayam
48	3	CUDDALORE	72	Chidambaram	35	Kumaratchi
49	3	CUDDALORE	73	Vadalur	36	Kurinjipadi
50	3	CUDDALORE	66	Virudhachalam	37	Mangalore
51	3	CUDDALORE	66	Virudhachalam	38	Nallur
52	3	CUDDALORE	73	Vadalur	39	Neyveli
53	3	CUDDALORE	13	Cuddalore	40	Panruti
54	3	CUDDALORE	72	Chidambaram	41	Parangipettai
55	3	CUDDALORE	66	Virudhachalam	42	Virudhachalam
56	9	DHARMAPURI	15	Dharmapuri	160	Dharmapuri
57	9	DHARMAPURI	15	Dharmapuri	161	Nallampalli
58	9	DHARMAPURI	15	Dharmapuri	162	Pennagaram
59	9	DHARMAPURI	75	Palacode	163	Palacode
60	9	DHARMAPURI	75	Palacode	164	Karimangalam
61	9	DHARMAPURI	74	Harur	165	Morappur
62	9	DHARMAPURI	74	Harur	166	Harur
63	9	DHARMAPURI	74	Harur	167	Pappireddipatti
64	22	DINDIGUL	76	Batlagundu	308	Batlagundu
65	22	DINDIGUL	16	Dindigul	311	Natham
66	22	DINDIGUL	16	Dindigul	313	Sanarpatty
67	22	DINDIGUL	36	Palani	314	Thoppampatty
68	22	DINDIGUL	77	Vedasandur	315	Vadamadurai
69	22	DINDIGUL	77	Vedasandur	316	Vedasandur
70	22	DINDIGUL	76	Batlagundu	317	Athoor
71	22	DINDIGUL	36	Palani	318	Oddanchathram
72	22	DINDIGUL	16	Dindigul	319	Dindigul - Rural
73	22	DINDIGUL	16	Dindigul	320	Dindigul -Urban
74	22	DINDIGUL	36	Palani	321	Palani - Rural
75	22	DINDIGUL	36	Palani	322	Palani - Urban
76	22	DINDIGUL	77	Vedasandur	323	Reddiyarchatram
77	22	DINDIGUL	77	Vedasandur	324	Gujiliamparai
78	22	DINDIGUL	76	Batlagundu	325	Nilakottai
79	22	DINDIGUL	76	Batlagundu	326	Kodaikanal
80	10	ERODE	17	Erode	168	Erode

Sl. No.	Dist_id	District_name	Edu_dist_id	Edn_dist_name	Blk_id	Block_name
81	10	ERODE	18	Gobichettipalayam	169	Gobi
82	10	ERODE	17	Erode	170	Kodumudi
83	10	ERODE	17	Erode	171	Modakurichi
84	10	ERODE	18	Gobichettipalayam	172	Nambiyur
85	10	ERODE	80	Perundurai	173	Perundurai
86	10	ERODE	79	Sathiyamangalam	174	Sathiyamangalam
87	10	ERODE	18	Gobichettipalayam	175	Thuckanaicken Palayam
88	10	ERODE	79	Sathiyamangalam	176	Thalavady
89	10	ERODE	78	Bhavani	177	Anthiyur
90	10	ERODE	78	Bhavani	178	Bhavani
91	10	ERODE	79	Sathiyamangalam	179	Bhavani sagar
92	10	ERODE	80	Perundurai	180	Chennimalai
93	10	ERODE	78	Bhavani	181	Ammapettai-Erode
94	37	KALLAKURICHI	21	Kallakurichi	43	Chinnasalem
95	37	KALLAKURICHI	21	Kallakurichi	47	Kallakurichi
96	37	KALLAKURICHI	117	Thirukoilur	53	Rishivanthiyam
97	37	KALLAKURICHI	117	Thirukoilur	54	Thirukoilur
98	37	KALLAKURICHI	119	Ulundurpet	55	Thirunavalur
99	37	KALLAKURICHI	119	Ulundurpet	57	Ulundurpet
100	37	KALLAKURICHI	21	Kallakurichi	61	Sankarapuram
101	37	KALLAKURICHI	119	Ulundurpet	62	Thiyagadurgam
102	1	KANCHEEPURAM	22	Kancheepuram	1	Kancheepuram
103	1	KANCHEEPURAM	22	Kancheepuram	2	Walajabad
104	1	KANCHEEPURAM	22	Kancheepuram	3	Uthiramerur
105	1	KANCHEEPURAM	82	Sriperumbudur	4	Kundrathur
106	1	KANCHEEPURAM	82	Sriperumbudur	12	Sriperumbudur
107	28	KANNIYAKUMARI	54	Thuckalay	401	Rajakkamangalam
108	28	KANNIYAKUMARI	54	Thuckalay	402	Kurunthancode
109	28	KANNIYAKUMARI	54	Thuckalay	403	Thuckalay
110	28	KANNIYAKUMARI	84	Thiruvattar	404	Thiruvattar
111	28	KANNIYAKUMARI	84	Thiruvattar	405	Melpuram
112	28	KANNIYAKUMARI	27	Kuzhithurai	406	Killiyoor
113	28	KANNIYAKUMARI	27	Kuzhithurai	407	Munchirai
114	28	KANNIYAKUMARI	34	Nagercoil	408	Thovalai
115	28	KANNIYAKUMARI	34	Nagercoil	409	Agastheeswaram
116	17	KARUR	23	Karur	257	Karur
117	17	KARUR	85	Kulithalai	258	Kulithalai
118	17	KARUR	85	Kulithalai	259	Krishnarayapuram
119	17	KARUR	23	Karur	260	K.Paramathi
120	17	KARUR	85	Kulithalai	261	Kadavoor
121	17	KARUR	23	Karur	263	Aravakurichi
122	17	KARUR	23	Karur	264	Thanthoni
123	17	KARUR	85	Kulithalai	265	Thogaimalai
124	30	KRISHNAGIRI	87	Mathur	420	Uthangarai

Sl. No.	Dist_id	District_name	Edu_dist_id	Edn_dist_name	Blk_id	Block_name
125	30	KRISHNAGIRI	25	Krishnagiri	421	Krishnagiri
126	30	KRISHNAGIRI	87	Mathur	422	Bargur
127	30	KRISHNAGIRI	25	Krishnagiri	423	Veppanapalli
128	30	KRISHNAGIRI	20	Hosur	424	Shoolagiri
129	30	KRISHNAGIRI	20	Hosur	425	Hosur
130	30	KRISHNAGIRI	86	Thenkanikottai	426	Kelamangalam
131	30	KRISHNAGIRI	86	Thenkanikottai	427	Thally
132	30	KRISHNAGIRI	87	Mathur	428	Mathur
133	30	KRISHNAGIRI	25	Krishnagiri	429	Kaveripatinam
134	20	MADURAI	29	Madurai	284	Alanganallur
135	20	MADURAI	62	Usilampatti	285	Chellampatti
136	20	MADURAI	88	Thirumangalam	286	Kallikudi
137	20	MADURAI	31	Melur	287	Kottampatti
138	20	MADURAI	29	Madurai	288	Madurai North
139	20	MADURAI	29	Madurai	289	Madurai South
140	20	MADURAI	31	Melur	290	Madurai West
141	20	MADURAI	31	Melur	291	Melur
142	20	MADURAI	62	Usilampatti	292	Sedapatti
143	20	MADURAI	29	Madurai	293	T.vadipatti
144	20	MADURAI	62	Usilampatti	294	T.kallupatti
145	20	MADURAI	88	Thirumangalam	295	Thirumangalam
146	20	MADURAI	88	Thirumangalam	296	Thiruparamkundram
147	20	MADURAI	62	Usilampatti	297	Usilampatti
148	20	MADURAI	31	Melur	298	Madurai East
149	38	MAYILADUTHURAI	89	Sirkali	223	Sembanarkoil
150	38	MAYILADUTHURAI	30	Mayiladuthurai	224	Kuthalam
151	38	MAYILADUTHURAI	89	Sirkali	225	Sirkali
152	38	MAYILADUTHURAI	89	Sirkali	228	kollidam
153	38	MAYILADUTHURAI	30	Mayiladuthurai	229	Mayiladudurai
154	14	NAGAPATTINAM	33	Nagapattinam	219	Nagapattinam
155	14	NAGAPATTINAM	33	Nagapattinam	220	Thirumarugal
156	14	NAGAPATTINAM	33	Nagapattinam	221	Thalainayar
157	14	NAGAPATTINAM	33	Nagapattinam	222	Vedaranyam
158	14	NAGAPATTINAM	33	Nagapattinam	226	Keezhaiyur
159	14	NAGAPATTINAM	33	Nagapattinam	227	Kelvelur
160	8	NAMAKKAL	35	Namakkal	140	Kollihills
161	8	NAMAKKAL	35	Namakkal	141	Mohanur
162	8	NAMAKKAL	35	Namakkal	143	Sendamangalam
163	8	NAMAKKAL	35	Namakkal	145	Rasipuram
164	8	NAMAKKAL	90	Tiruchengode	146	Vennandur
165	8	NAMAKKAL	90	Tiruchengode	149	Pallipalayam
166	8	NAMAKKAL	90	Tiruchengode	150	Mallasamudram
167	8	NAMAKKAL	90	Tiruchengode	151	Elachipalayam
168	8	NAMAKKAL	90	Tiruchengode	152	Kabilarmalai

Sl. No.	Dist_id	District_name	Edu_dist_id	Edn_dist_name	Blk_id	Block_name
169	8	NAMAKKAL	35	Namakkal	153	Namakkal
170	8	NAMAKKAL	35	Namakkal	155	Erumapatti
171	8	NAMAKKAL	35	Namakkal	156	Namagiripet
172	8	NAMAKKAL	90	Tiruchengode	157	Paramathi
173	8	NAMAKKAL	35	Namakkal	158	Puduchatram
174	8	NAMAKKAL	90	Tiruchengode	159	Tiruchengode
175	18	PERAMBALUR	91	Veppur	266	Veppur
176	18	PERAMBALUR	39	Perambalur	267	Veppanthattai
177	18	PERAMBALUR	91	Veppur	268	Alathur
178	18	PERAMBALUR	39	Perambalur	269	Perambalur
179	19	PUDUKKOTTAI	43	Pudukkottai	271	Thirumayam
180	19	PUDUKKOTTAI	43	Pudukkottai	272	Pudukkottai
181	19	PUDUKKOTTAI	43	Pudukkottai	273	Karambakkudi
182	19	PUDUKKOTTAI	92	Eluppur	274	Viralimalai
183	19	PUDUKKOTTAI	1	Aranthangi	275	Avudaiyarkoil
184	19	PUDUKKOTTAI	92	Eluppur	276	Kunnandarkoil
185	19	PUDUKKOTTAI	43	Pudukkottai	277	Arimalam
186	19	PUDUKKOTTAI	43	Pudukkottai	278	Gandarvakkottai
187	19	PUDUKKOTTAI	92	Eluppur	279	Annavasal
188	19	PUDUKKOTTAI	1	Aranthangi	280	Aranthangi
189	19	PUDUKKOTTAI	1	Aranthangi	281	Manamelkudi
190	19	PUDUKKOTTAI	92	Eluppur	282	Ponnamaravathy
191	19	PUDUKKOTTAI	1	Aranthangi	283	Thirubarankulam
192	23	RAMANATHAPURAM	44	Ramanathapuram	327	Ramanathapuram
193	23	RAMANATHAPURAM	37	Paramakudi	328	Bogalur
194	23	RAMANATHAPURAM	93	Mandapam	329	Kadaladi
195	23	RAMANATHAPURAM	37	Paramakudi	330	Kamuthi
196	23	RAMANATHAPURAM	93	Mandapam	331	Mandapam
197	23	RAMANATHAPURAM	37	Paramakudi	332	Mudukulathur
198	23	RAMANATHAPURAM	44	Ramanathapuram	333	Nainarkoil
199	23	RAMANATHAPURAM	37	Paramakudi	334	Paramakudi
200	23	RAMANATHAPURAM	44	Ramanathapuram	335	Rajasingamangalam
201	23	RAMANATHAPURAM	93	Mandapam	336	Thiruppullani
202	23	RAMANATHAPURAM	44	Ramanathapuram	337	Thiruvadana
203	35	RANIPET	114	Arakkonam	67	Arakkonam
204	35	RANIPET	115	Ranipettai	68	Arcot
205	35	RANIPET	114	Arakkonam	75	Kaveripakkam
206	35	RANIPET	114	Arakkonam	78	Nemili
207	35	RANIPET	115	Ranipettai	81	Timiri
208	35	RANIPET	115	Ranipettai	84	Walaja West
209	35	RANIPET	115	Ranipettai	94	Sholingar
210	35	RANIPET	115	Ranipettai	95	Walaja East
211	7	SALEM	96	Attur	116	Attur
212	7	SALEM	94	Edappadi	117	Edappadi



Sl. No.	Dist_id	District_name	Edu_dist_id	Edn_dist_name	Blk_id	Block_name
213	7	SALEM	96	Attur	118	Gangavalli
214	7	SALEM	94	Edappadi	120	Konganapuram
215	7	SALEM	94	Edappadi	121	Kolathur
216	7	SALEM	94	Edappadi	122	Mecheri
217	7	SALEM	94	Edappadi	123	Nangavalli
218	7	SALEM	45	Salem(Rural)	124	Omalur
219	7	SALEM	45	Salem(Rural)	125	Panamarathupatti
220	7	SALEM	45	Salem(Rural)	126	Salem-Rural
221	7	SALEM	46	Sankari	127	Sankari
222	7	SALEM	96	Attur	128	Thalaivasal
223	7	SALEM	46	Sankari	129	Tharamangalam
224	7	SALEM	95	Salem(Urban)	130	Valappadi
225	7	SALEM	46	Sankari	131	Veerapandi
226	7	SALEM	95	Salem(Urban)	132	Yercaud
227	7	SALEM	95	Salem(Urban)	133	Salem-Urban
228	7	SALEM	95	Salem(Urban)	134	Ayothiyapattinam
229	7	SALEM	46	Sankari	135	Magudanchavadi
230	7	SALEM	96	Attur	137	Pethanaickenpalayam
231	7	SALEM	45	Salem(Rural)	139	Kadayampatti
232	25	SIVAGANGAI	47	Sivagangai	351	Sivagangai
233	25	SIVAGANGAI	47	Sivagangai	352	Manamadurai
234	25	SIVAGANGAI	47	Sivagangai	353	Thiruppuvanam
235	25	SIVAGANGAI	14	Devakottai	354	Devakottai
236	25	SIVAGANGAI	14	Devakottai	355	Kannangudi
237	25	SIVAGANGAI	14	Devakottai	356	Sakkottai
238	25	SIVAGANGAI	97	Thirupattur	357	Singampunari
239	25	SIVAGANGAI	97	Thirupattur	358	S.Pudur
240	25	SIVAGANGAI	97	Thirupattur	359	Kallal
241	25	SIVAGANGAI	47	Sivagangai	360	Ilayangudi
242	25	SIVAGANGAI	97	Thirupattur	361	Thirupattur
243	25	SIVAGANGAI	14	Devakottai	362	Kalayarkoil
244	36	TENKASI	102	Sankarankovil	363	Alangulam
245	36	TENKASI	49	Tenkasi	366	Kadayam
246	36	TENKASI	49	Tenkasi	367	Kadayanallur
247	36	TENKASI	49	Tenkasi	369	Keelapavoor
248	36	TENKASI	102	Sankarankovil	370	Kuruvikulam
249	36	TENKASI	102	Sankarankovil	372	Melaneelithanallur
250	36	TENKASI	102	Sankarankovil	377	Sankarankovil
251	36	TENKASI	49	Tenkasi	378	Shenkottai
252	36	TENKASI	49	Tenkasi	379	Tenkasi
253	36	TENKASI	102	Sankarankovil	381	Vasudevanallur
254	13	THANJAVUR	50	Thanjavur	203	Thanjavur(Urban)
255	13	THANJAVUR	50	Thanjavur	204	Thanjavur(Rural)
256	13	THANJAVUR	50	Thanjavur	206	Budalur

Sl. No.	Dist_id	District_name	Edu_dist_id	Edn_dist_name	Blk_id	Block_name
257	13	THANJAVUR	98	Orathanadu	207	Orathanadu
258	13	THANJAVUR	98	Orathanadu	208	Thiruvonam
259	13	THANJAVUR	26	Kumbakonam	209	Kumbakonam
260	13	THANJAVUR	26	Kumbakonam	210	Papanasam
261	13	THANJAVUR	26	Kumbakonam	211	Thiruvudaimarudhur
262	13	THANJAVUR	26	Kumbakonam	212	Thiruppanandal
263	13	THANJAVUR	38	Pattukottai	213	Pattukkottai
264	13	THANJAVUR	38	Pattukottai	214	Madukkur
265	13	THANJAVUR	38	Pattukottai	215	Peravurani
266	13	THANJAVUR	38	Pattukottai	216	Sethubavachatram
267	13	THANJAVUR	98	Orathanadu	217	Ammapettai-TNJ
268	13	THANJAVUR	50	Thanjavur	218	Thiruvaiyar
269	12	THE NILGIRIS	12	Coonoor	198	Kotagiri
270	12	THE NILGIRIS	12	Coonoor	199	Coonoor
271	12	THE NILGIRIS	19	Gudalur	200	Gudalur
272	12	THE NILGIRIS	12	Coonoor	201	Udhagamandalam
273	21	THENI	40	Periyakulam	299	Aundipatty
274	21	THENI	99	Theni	300	Bodinayakanur
275	21	THENI	63	Uthamapalayam	301	Chinnamanur
276	21	THENI	63	Uthamapalayam	302	Cumbum
277	21	THENI	99	Theni	303	Myladumparai
278	21	THENI	99	Theni	304	Theni
279	21	THENI	63	Uthamapalayam	306	Uthamapalayam
280	21	THENI	40	Periyakulam	307	Periyakulam
281	27	THOOTHUKKUDI	53	Thoothukudi	385	Karunkulam
282	27	THOOTHUKKUDI	24	Kovilpatti	386	Kayathar
283	27	THOOTHUKKUDI	24	Kovilpatti	387	Kovilpatti
284	27	THOOTHUKKUDI	53	Thoothukudi	388	Ottapidaram
285	27	THOOTHUKKUDI	24	Kovilpatti	389	Pudur
286	27	THOOTHUKKUDI	100	Thiruchenthur	390	Sathankulam
287	27	THOOTHUKKUDI	100	Thiruchenthur	391	Thiruchenthur
288	27	THOOTHUKKUDI	53	Thoothukudi	392	Thoothukudi Rural
289	27	THOOTHUKKUDI	100	Thiruchenthur	393	Udangudi
290	27	THOOTHUKKUDI	24	Kovilpatti	394	Vilathikulam
291	27	THOOTHUKKUDI	53	Thoothukudi	395	Thoothukudi Urban
292	27	THOOTHUKKUDI	100	Thiruchenthur	398	Alwarthirunagar
293	27	THOOTHUKKUDI	53	Thoothukudi	399	Srivaikundam
294	16	TIRUCHIRAPPALLI	101	Manapparai	240	Manikandam
295	16	TIRUCHIRAPPALLI	56	Tiruchirappalli	241	Andhanallur
296	16	TIRUCHIRAPPALLI	101	Manapparai	242	Manapparai
297	16	TIRUCHIRAPPALLI	28	Lalgudi	243	Lalgudi
298	16	TIRUCHIRAPPALLI	28	Lalgudi	244	Mannachanallur
299	16	TIRUCHIRAPPALLI	101	Manapparai	245	Marungapuri
300	16	TIRUCHIRAPPALLI	32	Musiri	246	Musiri

Sl. No.	Dist_id	District_name	Edu_dist_id	Edn_dist_name	Blk_id	Block_name
301	16	TIRUCHIRAPPALLI	28	Lalgudi	247	Pullambadi
302	16	TIRUCHIRAPPALLI	56	Tiruchirappalli	248	Trichy-Urban
303	16	TIRUCHIRAPPALLI	56	Tiruchirappalli	249	Trichy-West
304	16	TIRUCHIRAPPALLI	56	Tiruchirappalli	250	Thiruverumbur
305	16	TIRUCHIRAPPALLI	32	Musiri	251	Thottiyam
306	16	TIRUCHIRAPPALLI	28	Lalgudi	252	Thuraiyur
307	16	TIRUCHIRAPPALLI	101	Manapparai	254	Vaiyampatti
308	16	TIRUCHIRAPPALLI	32	Musiri	255	Thathiengarpet
309	16	TIRUCHIRAPPALLI	32	Musiri	256	Uppiliyapuram
310	26	TIRUNELVELI	9	Cheranmahadevi	364	Ambasamudram
311	26	TIRUNELVELI	9	Cheranmahadevi	365	Cheranmahadevi
312	26	TIRUNELVELI	103	Valliyoor	368	Kalakad
313	26	TIRUNELVELI	57	Tirunelveli	371	Manur
314	26	TIRUNELVELI	103	Valliyoor	373	Nanguneri
315	26	TIRUNELVELI	57	Tirunelveli	374	Palay-Rural
316	26	TIRUNELVELI	9	Cheranmahadevi	375	Pappakudi
317	26	TIRUNELVELI	103	Valliyoor	376	Radhapuram
318	26	TIRUNELVELI	103	Valliyoor	380	Valliyoor
319	26	TIRUNELVELI	57	Tirunelveli	382	Palay-Urban
320	26	TIRUNELVELI	57	Tirunelveli	384	Tirunelveli Urban
321	34	TIRUPATHUR	58	Tiruppattur	70	Jolarpet
322	34	TIRUPATHUR	58	Tiruppattur	72	Kandhili
323	34	TIRUPATHUR	116	Vaniyambadi	76	Madhanur
324	34	TIRUPATHUR	116	Vaniyambadi	77	Natrampalli
325	34	TIRUPATHUR	58	Tiruppattur	80	Tirupathur
326	34	TIRUPATHUR	58	Tiruppattur	93	Alangayam
327	32	TIRUPPUR	104	Palladam	437	Palladam
328	32	TIRUPPUR	59	Tiruppur	438	Tiruppur
329	32	TIRUPPUR	59	Tiruppur	439	Uthukuli
330	32	TIRUPPUR	59	Tiruppur	440	Avinashi
331	32	TIRUPPUR	105	Dharapuram	441	Mulanur
332	32	TIRUPPUR	105	Dharapuram	442	Vellakovil
333	32	TIRUPPUR	104	Palladam	443	Kangayam
334	32	TIRUPPUR	104	Palladam	444	Pongalur
335	32	TIRUPPUR	106	Udumalaipattai	445	Udumalpet
336	32	TIRUPPUR	106	Udumalaipattai	446	Madathukulam
337	32	TIRUPPUR	105	Dharapuram	447	Kundadam
338	32	TIRUPPUR	106	Udumalaipattai	448	Gudimangalam
339	32	TIRUPPUR	105	Dharapuram	449	Dharapuram
340	2	TIRUVALLUR	51	Thiruvallur	15	Thiruvallur
341	2	TIRUVALLUR	51	Thiruvallur	16	Poondi
342	2	TIRUVALLUR	51	Thiruvallur	17	Kadambathur
343	2	TIRUVALLUR	108	Avadi	18	Ellapuram
344	2	TIRUVALLUR	108	Avadi	19	Poonamallee

Sl. No.	Dist_id	District_name	Edu_dist_id	Edn_dist_name	Blk_id	Block_name
345	2	TIRUVALLUR	42	Ponneri	20	Minjur
346	2	TIRUVALLUR	42	Ponneri	21	Sholavaram
347	2	TIRUVALLUR	42	Ponneri	22	Gummidipoondi
348	2	TIRUVALLUR	109	Ambattur	23	Villivakkam
349	2	TIRUVALLUR	109	Ambattur	24	Puzhal
350	2	TIRUVALLUR	107	Tiruttani	25	Tiruttani
351	2	TIRUVALLUR	107	Tiruttani	26	Thiruvallangadu
352	2	TIRUVALLUR	107	Tiruttani	27	Pallipat
353	2	TIRUVALLUR	107	Tiruttani	28	R.K.Pet
354	6	TIRUVANNAMALAI	10	Cheyyar	98	Vandavasi
355	6	TIRUVANNAMALAI	10	Cheyyar	99	Anakkavur
356	6	TIRUVANNAMALAI	10	Cheyyar	100	Cheyyar
357	6	TIRUVANNAMALAI	110	Arni	101	Peranamallur
358	6	TIRUVANNAMALAI	110	Arni	102	Thellar
359	6	TIRUVANNAMALAI	10	Cheyyar	103	Vembakkam
360	6	TIRUVANNAMALAI	110	Arni	104	Arni
361	6	TIRUVANNAMALAI	110	Arni	105	West Arni
362	6	TIRUVANNAMALAI	111	Polur	106	Polur
363	6	TIRUVANNAMALAI	111	Polur	107	Kalaspakkam
364	6	TIRUVANNAMALAI	111	Polur	108	Chetpet
365	6	TIRUVANNAMALAI	60	Tiruvannamalai	109	Thurinjapuram
366	6	TIRUVANNAMALAI	60	Tiruvannamalai	110	Kilpennathur
367	6	TIRUVANNAMALAI	60	Tiruvannamalai	111	Tiruvannamalai
368	6	TIRUVANNAMALAI	112	Chengam	112	Pudupalayam
369	6	TIRUVANNAMALAI	112	Chengam	113	Chengam
370	6	TIRUVANNAMALAI	112	Chengam	114	Thandrapet
371	6	TIRUVANNAMALAI	111	Polur	115	Jawadhu Hills
372	15	TIRUVARUR	52	Thiruvarur	230	Valangaiman
373	15	TIRUVARUR	52	Thiruvarur	231	Kudavasal
374	15	TIRUVARUR	52	Thiruvarur	232	Koradachery
375	15	TIRUVARUR	52	Thiruvarur	233	Nannilam
376	15	TIRUVARUR	52	Thiruvarur	234	Thiruvarur
377	15	TIRUVARUR	113	Mannargudi	235	Mannargudi
378	15	TIRUVARUR	113	Mannargudi	236	Needamangalam
379	15	TIRUVARUR	113	Mannargudi	237	Kottur
380	15	TIRUVARUR	113	Mannargudi	238	Thiruthuraiipoondi
381	15	TIRUVARUR	113	Mannargudi	239	Muthupettai
382	5	VELLORE	64	Vellore	66	Anaicut
383	5	VELLORE	64	Vellore	69	Gudiyatham
384	5	VELLORE	64	Vellore	71	K.V.Kuppam
385	5	VELLORE	64	Vellore	73	Kaniyambadi
386	5	VELLORE	64	Vellore	74	Katpadi
387	5	VELLORE	64	Vellore	79	Pernambut
388	5	VELLORE	64	Vellore	82	Vellore Rural

Sl. No.	Dist_id	District_name	Edu_dist_id	Edn_dist_name	Blk_id	Block_name
389	5	VELLORE	64	Vellore	86	Vellore Urban
390	4	VILLUPURAM	118	Gingee	44	Gingee
391	4	VILLUPURAM	65	Viluppuram	45	Kanai
392	4	VILLUPURAM	65	Viluppuram	46	Kandamangalam
393	4	VILLUPURAM	65	Viluppuram	48	Kolliyanur
394	4	VILLUPURAM	55	Tindivanam	49	Mailam
395	4	VILLUPURAM	55	Tindivanam	50	Marakkanam
396	4	VILLUPURAM	65	Viluppuram	51	Mugaiyur
397	4	VILLUPURAM	55	Tindivanam	52	Olakkur
398	4	VILLUPURAM	65	Viluppuram	56	Thiruvannainallur
399	4	VILLUPURAM	118	Gingee	58	Vallam
400	4	VILLUPURAM	118	Gingee	60	Melmalayanur
401	4	VILLUPURAM	65	Viluppuram	63	Vikaravandi
402	4	VILLUPURAM	65	Viluppuram	64	Viluppuram
403	4	VILLUPURAM	55	Tindivanam	65	Vaanur
404	24	VIRUDHUNAGAR	3	Aruppukottai	338	Aruppukottai
405	24	VIRUDHUNAGAR	3	Aruppukottai	340	Narikudi
406	24	VIRUDHUNAGAR	48	Srivilliputhur	341	Rajapalayam
407	24	VIRUDHUNAGAR	67	Virudhunagar	342	Sattur
408	24	VIRUDHUNAGAR	120	Sivakasi	343	Sivakasi
409	24	VIRUDHUNAGAR	48	Srivilliputhur	344	Srivilliputhur
410	24	VIRUDHUNAGAR	3	Aruppukottai	345	Thiruchuli
411	24	VIRUDHUNAGAR	120	Sivakasi	346	Vembakottai
412	24	VIRUDHUNAGAR	120	Sivakasi	348	Watrap
413	24	VIRUDHUNAGAR	67	Virudhunagar	349	Virudhunagar
414	24	VIRUDHUNAGAR	67	Virudhunagar	350	Kariyapatti

### List of District Educational Offices (DEO) in Tamil Nadu

Sl.No.	Name of the District	Name of the DEO Office
1	ARIYALUR	ARIYALUR
2		UDIYARPALAYAM
3		SENDURAI
4	CHENNAI	DEO NORTH
5		DEO CENTRAL
6		DEO SOUTH
7		DEO W EST
8		DEO EAST
9	CHENGALPATTU	CHENGALPATTU
10		MADURANTHAKAM
11		ST.THOMAS MOUNT
12	COIMBATORE	POLLACHI

Sl.No.	Name of the District	Name of the DEO Office
13		COIMBATORE
14		S.S.KULAM
15		PERUR
16	CUDDALORE	CHIDAMBARAM
17		CUDDALORE
18		VADALUR
19		VRIDHACHALAM
20	DHARMAPURI	DHARMAPURI
21		HARUR
22		PALACODE
23	DINDIGUL	DINDIGUL
24		PALANI
25		BATLAGUNDU
26		VEDASANDUR
27	ERODE	ERODE
28		PERUNDURAI
29		BHAVANI
30		GOBICHETTIPALAYAM
31		SATHYAMANGALAM
32	KALLAKURICHI	KALLAKURICHI
33		TIRUKOVILUR
34		ULUNDURPET
35	KANCHIPURAM	KANCHIPURAM
36		SRIPERUMBUDUR
37	KANNIYAKUMARI	NAGERCOIL
38		THUCKLAY
39		KUZHITHURAI
40		THIRUVATTAR
41	KARUR	KARUR
42		KULITHALAI
43	KRISHNAGIRI	KRISHNAGIRI
44		HOSUR
45		MATHUR
46		DENKANIKOTTAI
47	MADURAI	MADURAI
48		MELUR
49		USILAMPATTI
50		THIRUMANGALAM
51	NAGAPATTINAM	NAGAPATTINAM
52		MAYILADUTHURAI
53		SIRKALI
54	NAMAKKAL	NAMAKKAL
55		TIRUCHENGODE
56	NILGIRIS	COONOR
57		GUDALUR
58	PERAMBALUR	PERAMBALUR
59		VEPPUR

Sl.No.	Name of the District	Name of the DEO Office
60	PUDUKKOTTAI	PUDUKKOTTAI
61		ARANTHANGI
62		ILLUPPUR
63	RAMNAD	RAMNAD
64		PARAMAKUDI
65		MANDAPAM
66	RANIPET	RANIPET
67		ARAKKONAM
68	SALEM	SALEM
69		SALEM RURAL
70		ATTUR
71		SANKARI
72		EDAPPADI
73	SIVAGANGAI	DEVAKOTTAI
74		THIRUPPATHUR
75		SIVAGANGAI
76	THANJAVUR	THANJAVUR
77		ORATHANADU
78		PATTUKKOTTAI
79		KUMBAKONAM
80	THENI	THENI
81		UTHAMAPALAYAM
82		PERIYAKULAM
83	TENKASI	TENKASI
84		SANKARANKOVIL
85	TIRUNELVELI	TIRUNELVELI
86		VALLIYOOR
87		CHERANMAHADEVI
88	TIRUPATTUR	TIRUPATTUR
89		VANIYAMPADI
90	TIRUPPUR	TIRUPPUR
91		PALLADAM
92		DHARAPURAM
93		UDUMALPET
94	THIRUVALLUR	PONNERI
95		THIRUVALLUR
96		AMBATHUR
97		AVADI
98		TIRUTTANI
99	TIRUVANNAMALAI	TIRUVANNAMALAI
100		CHENGAM
101		POLUR
102		CHEYAR
103	THIRUVARUR	ARANI
104		THIRUVARUR
105	TRICHY	MANNARGUDI
106		TRICHY

Sl.No.	Name of the District	Name of the DEO Office
107		LALGUDI
108		MUSIRI
109		MANAPPARAI
110	THOOTHUKUDI	THOOTHUKUDI
111		KOVILPATTI
112		TIRUCHENDUR
113	VELLORE	VELLORE
114	VILLUPURAM	VILLUPURAM
115		TINDIVANAM
116		GINGEE
117	VIRUDHUNAGAR	VIRUDHUNAGAR
118		ARUPPUKOTTAI
119		SRIVILLIPUTHUR
120		SIVAKASI



## ANNEXURE - XXII

**DELIVERY SCHEDULE FOR THE ORDERED QUANTITY**

(To be submitted within 5 days from the date of Purchase Order)

Delivery Milestone	Due date of Delivery / No. of days	Week No. 1 to 17 (120 / 7 days)	Delivery Quantity at Delivery Points (in Nos.)	Cumulative Delivery Quantity (in Nos.)	% of Cumulative Delivery Quantity to Total Purchase Order Qty.
25%	T+30 days	1			
		2			
		3			
		4			
		5			
		6			
		7			
		8			
50%	T+45 days	9			
		10			
		11			
75%	T+60 days	12			
		13			
		14			
100%	T+75 days	15			
		16			
		17			

**Signature of the Successful Tenderer  
(with Seal)**

**ANNEXURE - XXIII**

**UNDERTAKING TOWARDS JURISDICTION OF LEGAL PROCEEDINGS**

This Deed of undertaking executed at \_\_\_\_\_ on this day, \_\_\_\_\_ 2022 by M/s. \_\_\_\_\_ (Name and address of Tenderer), represented by its \_\_\_\_\_, Shri/Smt \_\_\_\_\_ hereinafter called the “**TENDERER**” (Which expression where the context so admits mean include their Agents, Representatives, Successors-in-office and Assigns).

TO AND IN FAVOUR OF

TAMILNADU TEXTBOOK AND EDUCATIONAL SERVICES CORPORATION, EVK Sampath Maaligai, DPI Campus, 68, College Road, Chennai - 600 006, hereinafter called the “**TNTB&ESC**” (Which expression shall where the context so admits mean and include the successors-in-office and assigns).

WHEREAS the **TNTB&ESC** has called for acceptance of jurisdiction of legal proceedings.

NOW THIS UNDERTAKING WITNESSETH that no suit or any proceedings in this regard in any matter arising in any respect under this contract shall be instituted in any court, save in appropriate Civil Court of Chennai or the Court of Small causes, Chennai. It is agreed that no other court shall have the jurisdiction to entertain any suit or proceedings, even though, part of the cause of action might arise within their jurisdiction. In case, any part of cause of action might arise within the jurisdiction of any of the courts in Tamil Nadu and not in the courts in Chennai City, then it is agreed between parties that such suits or proceedings shall be instituted in court within Tamil Nadu and no other court outside Tamil Nadu shall have jurisdiction, even though any part of the cause of action might arise within the jurisdiction of such courts.

IN WITNESS WHEREOF acting for \_\_\_\_\_ (Name of Tenderer) and on behalf of the **TENDERER** has signed this deed in the day, month and year hereinbefore first mentioned.

**Place:**

**Date:**

**Signature:**

**Name of Tenderer:**

**Address:**